

SAV
 SPAREPARTS
 KUNDENSERVICES
 POS VENTAS
 SERVICE NA VERKOOP
 SERVIZIO POST-VENDITA
 SERVIÇO DEPOIS DE VENDA
 SERVISU PO GWARANCYJNY
 POPRODĘNIU SERVIS
 ÉRTESÍTÉS UTÁNI SZOLGÁLTATÁS
 SERVICIU POST-VANZARE
 ПОСЛЕПРОДАЖНОЕ ОБСЛУЖИВАНИЕ
 POPRODAJNY SERVIS
 SATIS SONRASI HİZMET

364 748 - 01
 TREE BED

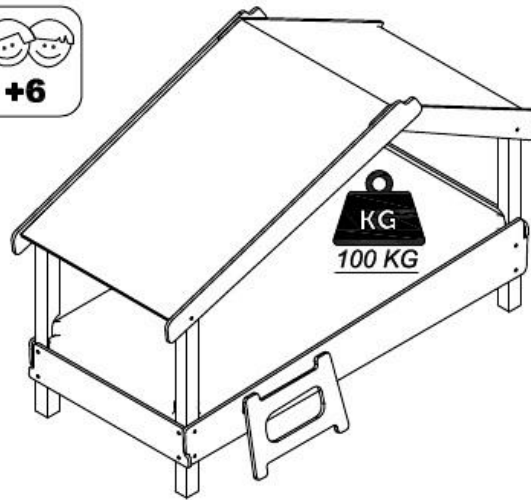

FR SECURITE
 RESPECTER LES INSTRUCTIONS DE MONTAGE DECRITES DANS LA NOTICE.
 CE LIT N'EST PAS UN JOUET. NE LAISSEZ PAS UN ENFANT ESCALADER LA STRUCTURE AU DESSUS DU COUCHAGE.

EN CAUTION
 FOLLOW CAREFULLY THE ASSEMBLY INSTRUCTIONS DESCRIBED IN THIS INSTRUCTION.
 BED NOT TO BE USED AS A GAME. DO NOT ALLOW THE CHILDREN TO CLIMB ONTO THE ROOF OF THE BED.

DE SICHERHEITSVORSCHRIFTEN
 BEACHTEN SIE BITTELUNGSBÜRO DIELE ANGEBOHRENEN ALPBAU VORSCHRIFTEN
 NICHT ALS SPIELGERÄT ZU VERWENDEN. LASSEN SIE DIE KINDER NICHT AUF DAS DACH DES BETTES STEIGEN.

ES SEGURIDAD
 RESPECTAR LAS INSTRUCCIONES DE MONTAJE DESCRIBIDAS EN EL FOLLETO.
 ESTA CAMA NO ES UN JUGUETO, NO DEJAD UN NIÑO SUBIR POR ENCIMA DE LA ESTRUCTURA DE LA CAMA.

NL VEILIGHEID
 DE FOLIE OEFENINGSAANWIJZING BESCHRIJVEN INSTRUCTIE RESPECTEREN
 HET BED IS GEEN SPEELTOEGESTEL. VERBODEN KINDEREN MOONTAAN HET DAK VAN HET BED KLIMMEN.

IT SICUREZZA
 RESPECTARE LE INSTRUZIONI DI MONTAGGIO DESCRITTE NELLA VISTORIA
 QUESTO LETTO NON È UN GIOCATTOLO. NON LASCIATE UN BAMBINO SCALARE LA STRUTTURA SOPRA IL LETTO.

PT SEGURANCA
 RESPECTAR AS INSTRUÇÕES DE MONTAGEM DESCRITAS NA INSTRUÇÃO DE USO
 ESTA CAMA NÃO É UM JOGO, NÃO DEVE SER UMA CRIANÇA ESCALAR A ESTRUTURA EM CIMA DA DORMIDA.

PL UWAGA
 PROSZĘ PRZECZYTAĆ INSTRUKCJĘ MONTAŻU
 TO ŁÓŻKO NIE JEST ZABAWKĄ. NIE POZWÓL, ABY DZIECKO WSPLEO SIĘ NA STRUKTURĘ LUB ŁÓŻKO.

CS BEZPEČNOST
 DODRŽUJTE MONTÁŽNÍ POKYNY UVEDENÉ V NÁVODU.
 NEPRAVTE SI NA STRANU LŮŽKA.

HU Biztonság
 KÖVETSE AZ ÖSSZEPUSZTÁS UTASÍTÁSOKAT,
 NE JÁRSSON AZ ÁGY TETEJÉRE.

RO Siguranță
 RESPECTATI INSTRUCȚIILE DE MONTARE DESCRISE ÎN MANUAL.
 NU VĂ JUCAȚI PE ACOPERȘUL PATULUI.

RU Безопасность
 СЛЕДИТЕ УКАЗАНИЯ ПО СБОРКЕ ОПИСАННЫМ В ИНСТРУКЦИИ,
 НЕ ПРАВАЙТЕ НА КРЫШЕ КРОВАТИ.

SK Bezpečnosť
 POSTUPUJTE PODĽA MONTÁŽNYCH POKYNOV UVEDENÝCH V NÁVODE.
 NEHRÁJTE SA NA STRANU POSTELE.

TR Güvenlik
 KAVAYUZA BİRLİKTEKİ MONTAJ TALİMATLARINA UYUN.
 YATAĞIN ÇATIŞI OZUNDA OYUN OYNAMAYIN.



MADE IN VIETNAM

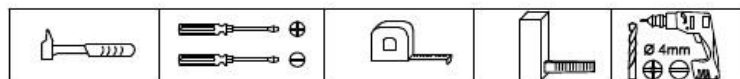

Français :

- Notice à conserver.
- En cours du montage, prenez garde aux risques de pincement et de cisaillement.
- Ne pas mettre le lit à proximité d'une source de chaleur.
- Ne pas s'asseoir à plusieurs sur le lit.
- Ne pas sauter sur le lit.
- Stocker le lit dans un endroit sec.
- Ne convient pas à un enfant de moins de 6 ans.
- Les meubles contenant des panneaux à base de bois (panneaux de particules, panneaux de fibres, contreplaqué...) peuvent émettre des substances polluantes dans l'air intérieur. Il est ainsi recommandé, après l'installation du meuble dans son logement, d'aérer fréquemment la pièce concernée pendant au moins quatre semaines afin de réduire son exposition aux polluants émis par le meuble.

English :

- Retain the Instructions for future reference.
- During the assembly, beware the risks of pinching and shearing.
- Keep the product away from heat sources.
- Do not sit on the bed several.
- Do not jump on the bed.
- Store the bed in a dry place.
- Not suitable for children under 6 years old.

Deutsch :

- Notiz zum Aufbewahren.
- Während der Montage bitte darauf achten sich nicht zu schneiden oder einzuklemmen das Bett nicht zu Nahe an einen Heizkörper stellen.
- Sich nicht gleichzeitig zu mehreren auf das Bett setzen.
- Nicht springen auf dem Bett.
- Das Bett an einem trockenen Platz aufbewahren.
- Nicht geeignet für Kinder unter 6 Jahren.

Español :

- Aviso .
- Durante el montaje, tenga cuidado con los riesgos de aplastamiento y cizallamiento.
- Fuente de fuego.
- No sentarse varias personas en la cama.
- No salte en la cama.
- Poner la cama en un lugar seco.
- No apto para niños menores de 6 años.

Nederlands :

- Bewaar deze instructie goed.
- Tijdens de montage, vermijd persen en drukken.
- Het bed niet naast een verwarmingsbron plaatsen.
- Niet met meerdere personen op het bed zitten.
- Niet op het bed springen.
- Het bed in een droge plaats bewaren.

Italy:

- Conservare le istruzioni per riferimenti futuri.
- Durante l'assemblea, attenzione i rischi di schiacciamento e di taglio.
- Tenere il prodotto lontano da fonti di calore .
- Non sedersi sul letto parecchi.
- Non saltare sul letto.
- Conservare il letto in un luogo asciutto.
- Non adatto a bambini sotto i 6 anni.

Poland :

- zachowaj instrukcje na przyszłość.
- Podczas montażu uważaj ryzyko zaciskające i ścinające.
- Produkt należy trzymać z dala od źródeł ciepła.
- Nie siadać na łóżku kilka.
- Nie skacz na łóżku.
- Łóżkoprzeczkowywać w suchym miejscu.
- Nie nadaje się dla dzieci poniżej 6 roku życia.

Portugal :

- Guarde as instruções para referência futura.*
- Durante a montagem, tenha cuidado com os riscos de beliscadura e de corte.*
- Mantenha o produto longe de fontes de calor.*
- Não se sentar na cama vários.*
- Não pule na cama.*
- Guarde a cama em um local seco.*
- Não recomendado para crianças menores de 6 anos de idade.*

Čeština:

- Návod si uschovejte.*
- Během montáže dávejte pozor na nebezpečí přiskřípnutí a pořezání. Lůžko neumisťujte do blízkosti zdroje tepla.*
- Na lůžko nesedejte ve více osobách.*
- Na lůžko neskákejte.*
- Lůžko skládejte na suchém místě.*
- Nevhodné pro děti mladší 6 let.*

Magyar:

- Tartsa be az utasítást*
- Az összeszerelés során vigyázzon a becsípődés és a vágás veszélyeire.*
- Ne helyezze az ágyat hőforrás közelébe.*
- Ne üljön az ágyra.*
- Ne ugorjon az ágyra.*
- Az ágyat száraz helyen tárolja.*
- Nem alkalmas 6 év alatti gyermek számára.*

Română:

- Manual de păstrat*
- În cursul montării, aveți grijă la riscurile de clupire și de tăiere.*
- Nu amplasați patul în apropiere de o sursă de căldură.*
- Nu vă așezați mai multe persoane pe pat.*
- Nu săriți pe pat.*
- Depozitați patul într-un loc uscat.*
- Nu se recomandă copililor mai mici de 6 ani.*

Русский:

- Важная информация*
- При сборке остерегайтесь риска защемления пальцев и порезов.*
- Не ставьте кровать рядом с источником тепла.*
- Нельзя сидеть на кровати более чем одному человеку.*
- Не прыгайте на кровати.*
- Храните кровать в сухом месте.*
- Не используйте для детей младше 6 лет.*

Slovenský:

- Návod si starostlivo uschovaajte.*
- Prí montáži si dávajte pozor na nebezpečenstvo pricviknutia a strihu.*
- Posteľ neumisťujte do blízkosti zdroja tepla.*
- Na posteľ si nesmie sadať viacero osôb súčasne.*
- Na posteli neskáčte.*
- Posteľ uskladnite na suchom mieste.*
- Nevhodné pre deti mladšie ako 6 roky.*

Türk:

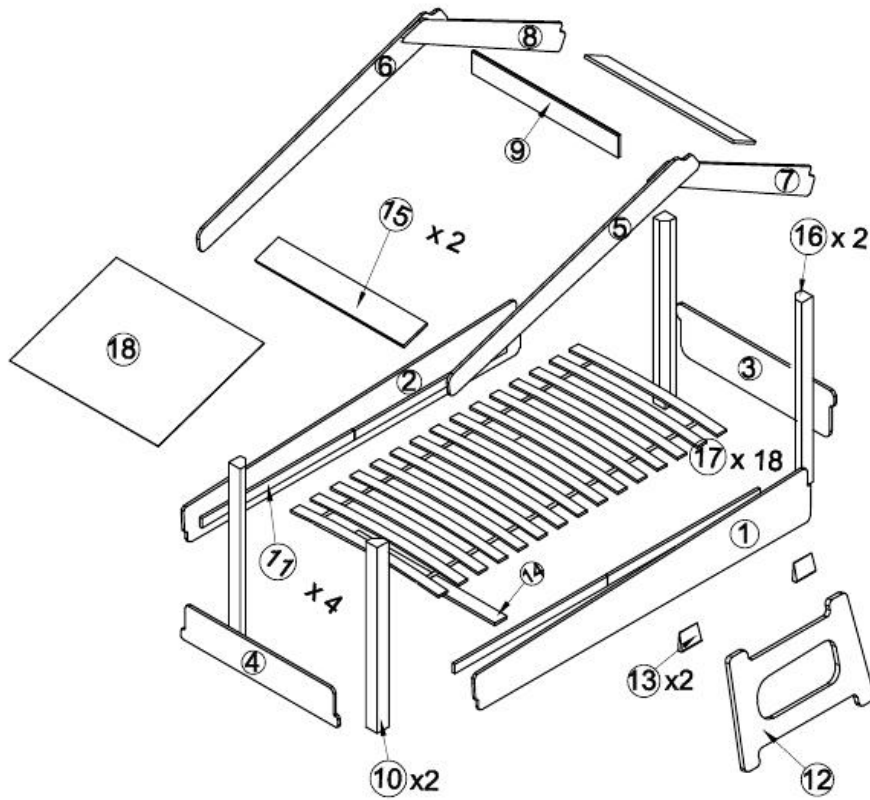

- Kılavuzu saklayın*
- Montaj sırasında sıkışma ve kesilme ile yaralanma tehlikelerine karşı dikkatli olun*
- Yatağı bir ısı kaynağı yakınına yerleştirmeyin*
- Yatak üzerine birden fazla kişi oturmamalıdır*
- Yatak üzerinde zıplamayın*
- Yatağı kuru bir ortamda muhafaza edin*
- 6 yaş altı çocuklar için uygun değildir*



REF	Dimension (mm)	Qty	REF	Dimension (mm)	Qty	REF	Dimension (mm)	Qty
1	2047*290*15	1	7	1110*135*15	1	13	78*63*18	2
2	2047*290*15	1	8	1110*135*15	1	14	902*76*15	1
3	956*260*15	1	9	1110*110*15	1	15	902*148*15	2
4	956*190*15	1	10	980*50*50	2	16	980*50*50	2
5	1597*155*15	1	11	944*50*15	4	17	Slat	18
6	1597*155*15	1	12	550*374*18	1	18	Fabric	1

ITEM	HARDWARE	DESCRIPTION	QTY
A		Ø6x20mm	28 PCS
B		Ø8x30 mm	44 PCS
C		Ø8x20 mm	8 PCS
D		TF Ø4 X 25 mm	22 PCS
E		Ø14.5x11.9 mm	16 PCS
F		Ø5x45 mm	16 PCS
G		Ø3x14 mm	8 PCS
H		15x30 mm	2 PCS
K		30x30 mm	4 PCS



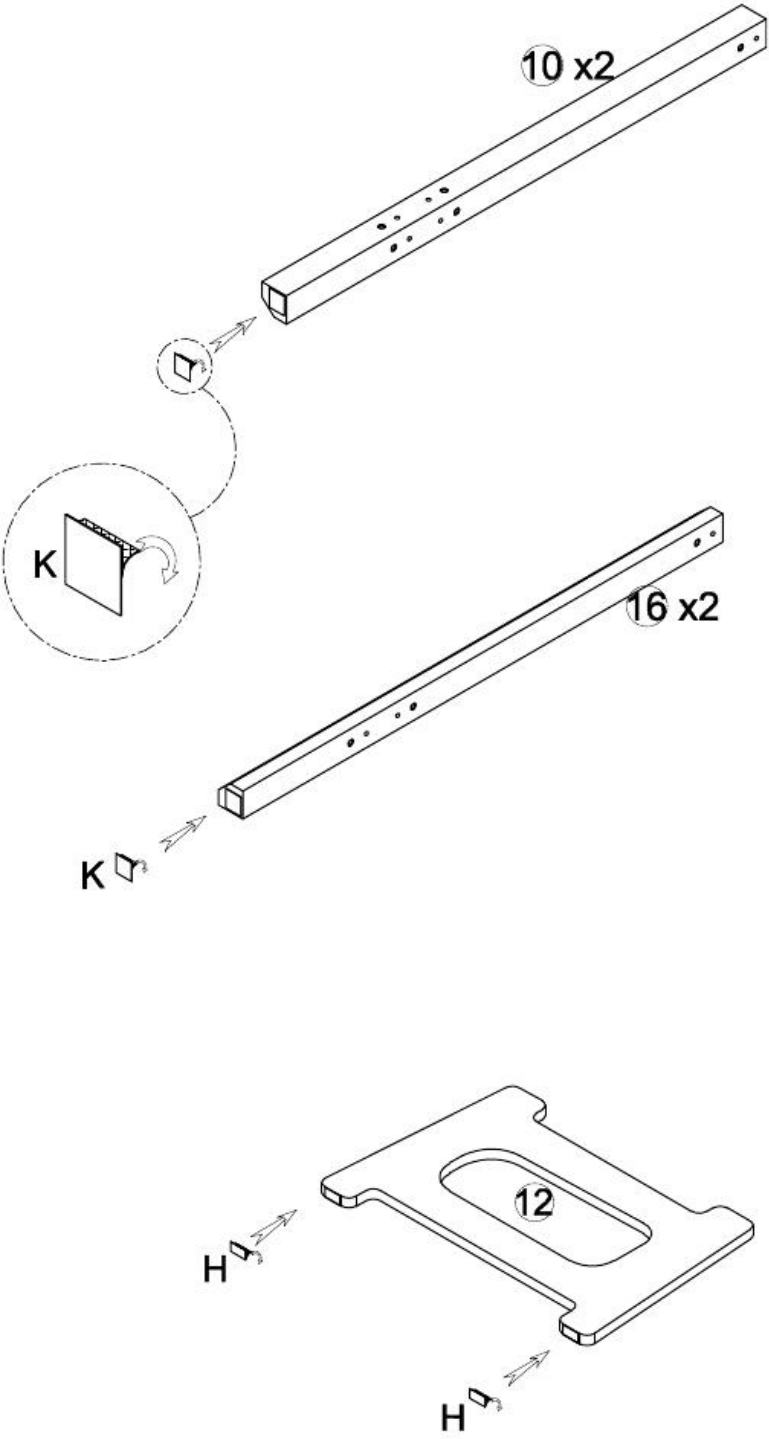

1

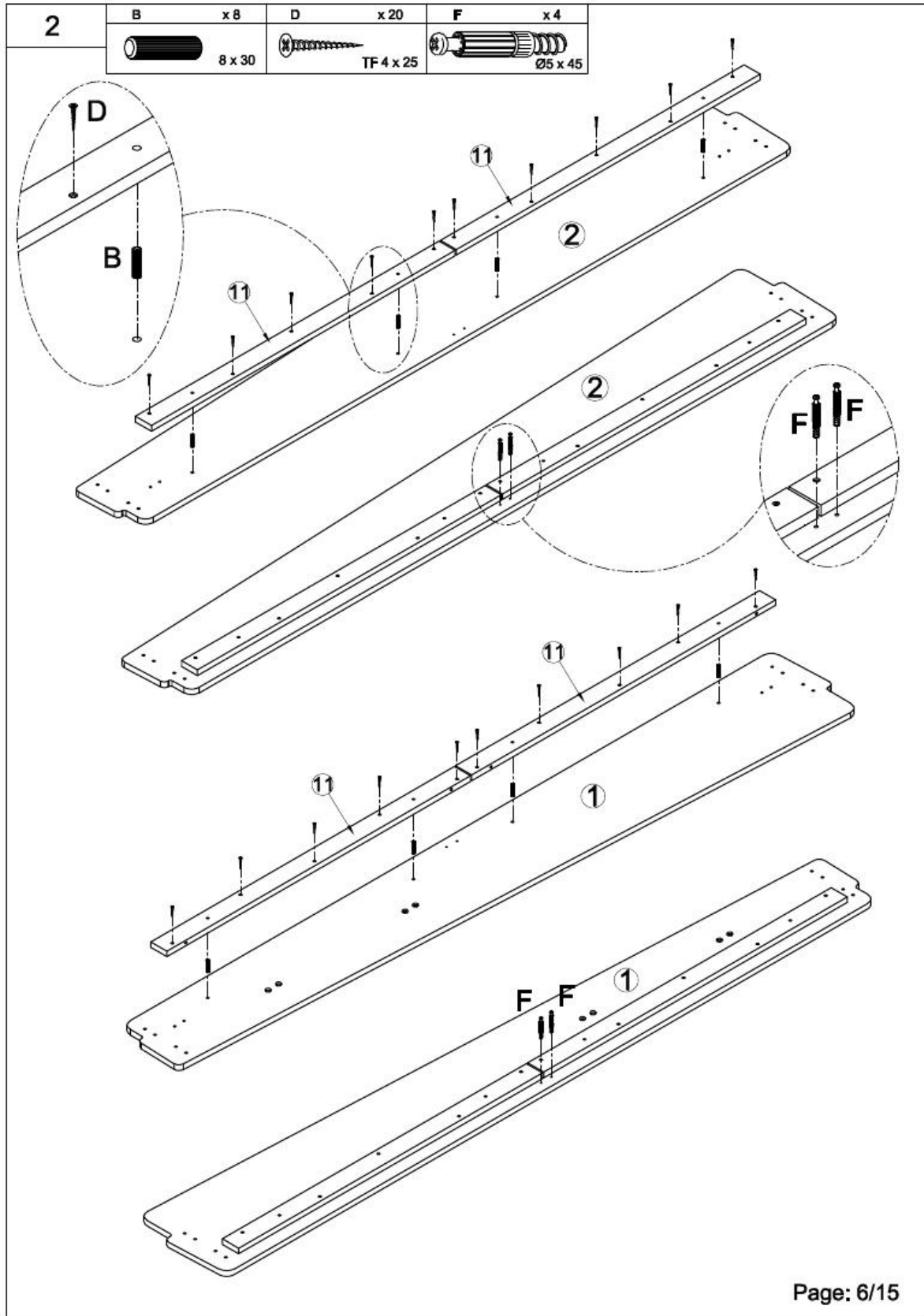
H	x2	K	x4
	15 x 30		30 x 30





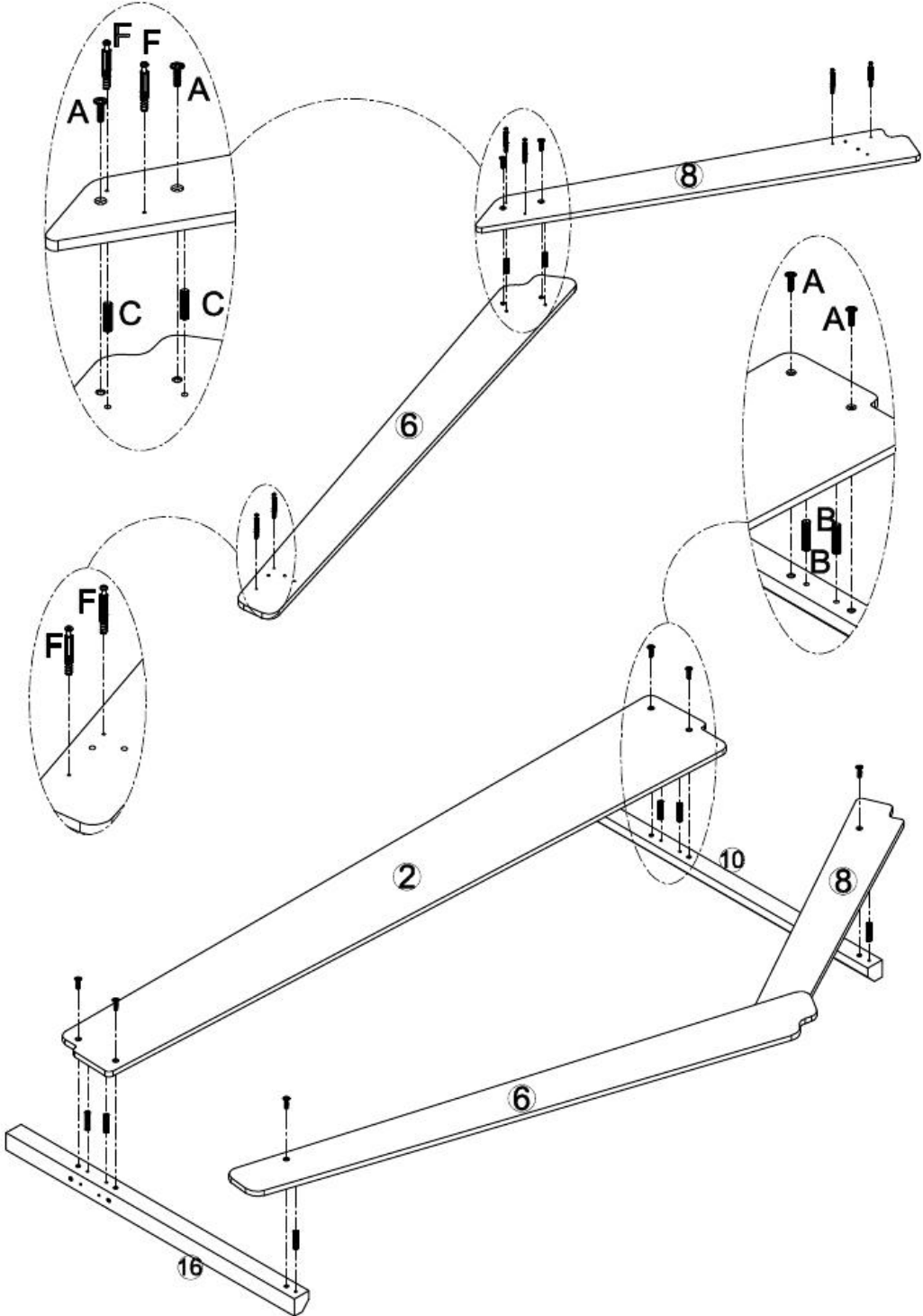

3

C	x2	F	x6	A	x8	B	x6
	8 x 20		Ø5 x 45		Ø6 x 20		8 x 30



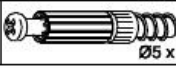

4

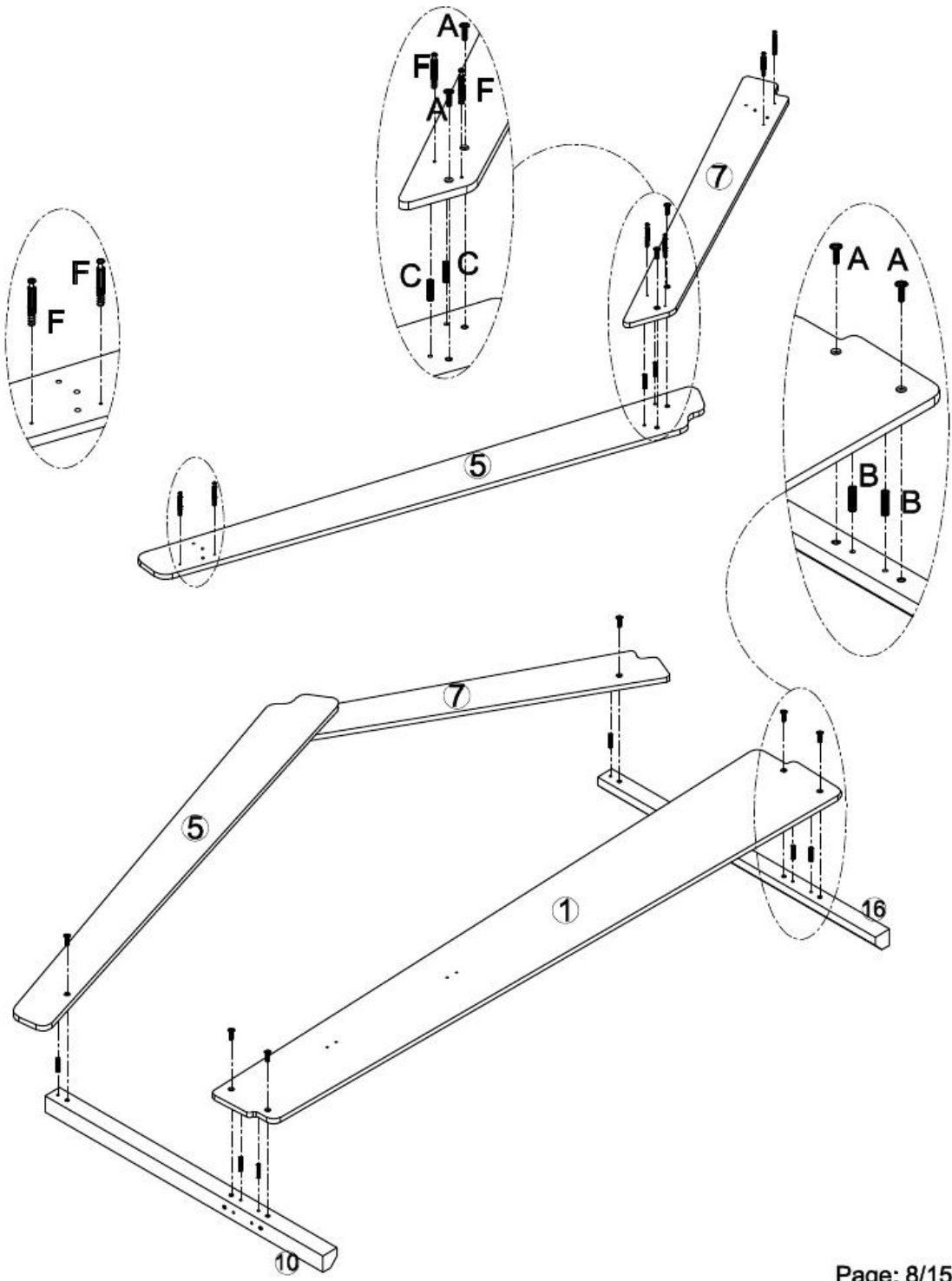
C	x2	F	x6	A	x8	B	x6
	8 x 20		Ø5 x 45		Ø6 x 20		8 x 30



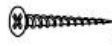

5

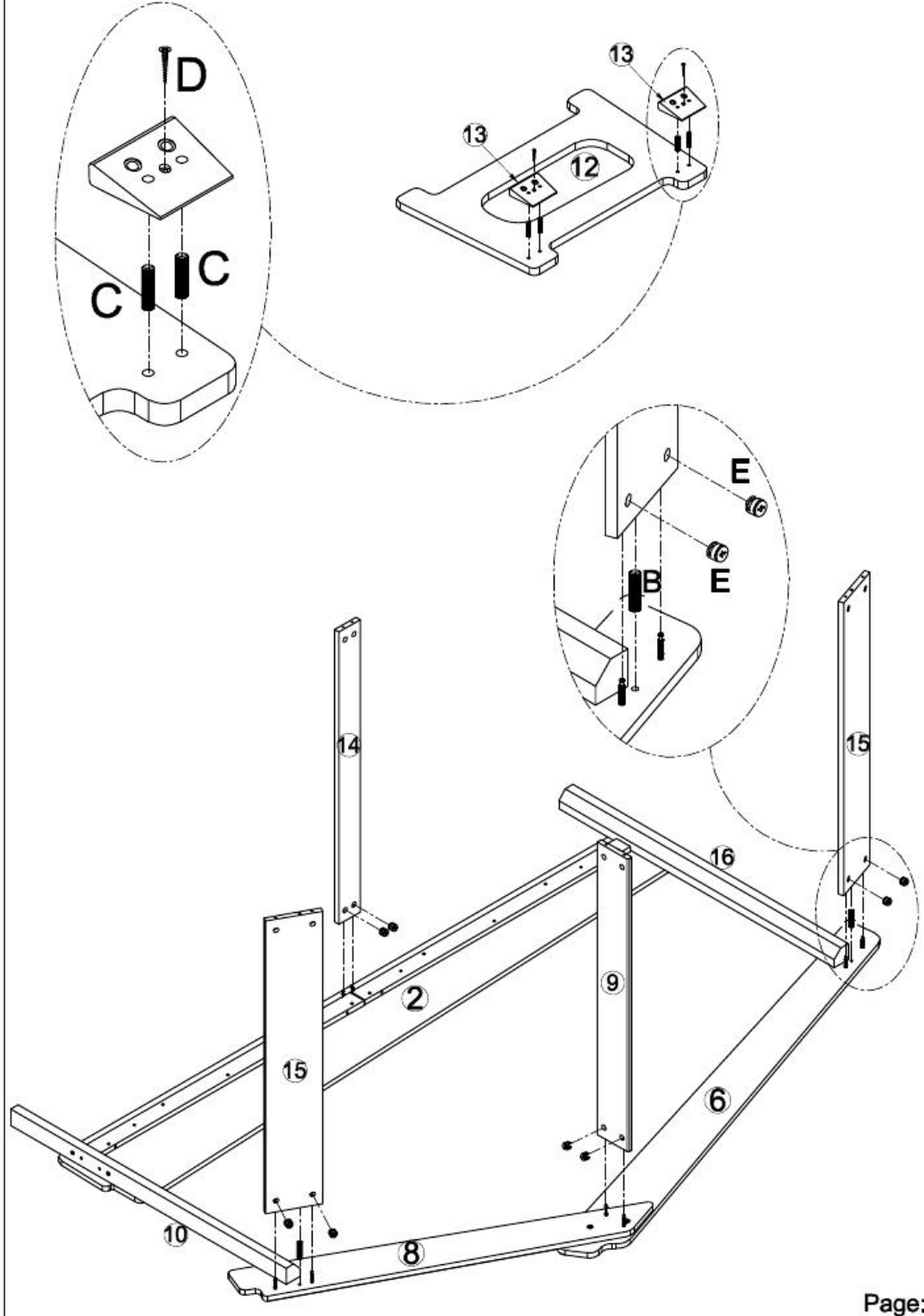
C	x4	D	x2	E	x8	B	x2
	8 x 20		TF 4 x 25		Ø14,5x11,9		8 x 30



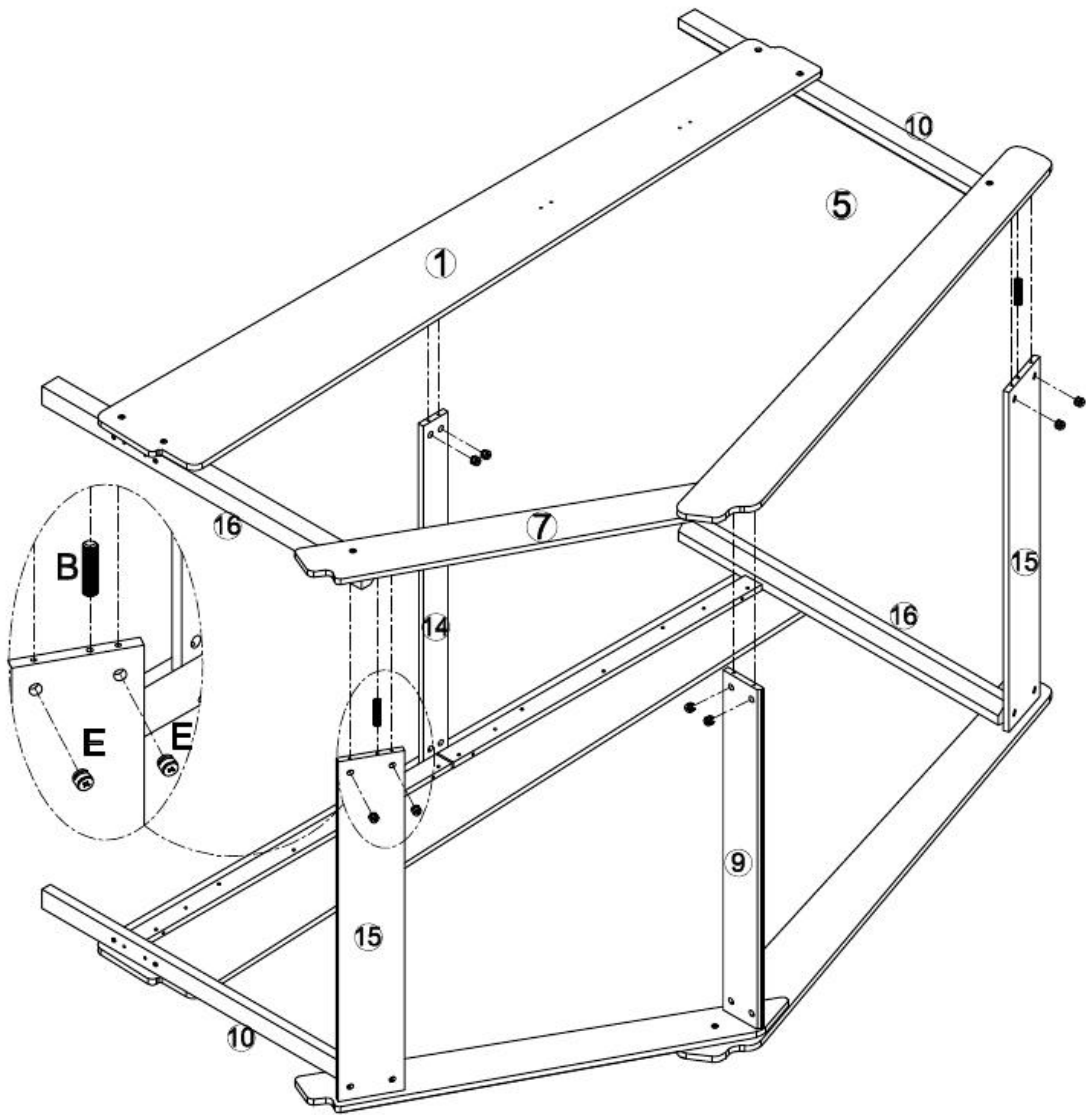

6

E	x8	B	x2
	Ø14,5x11,9		8 x 30



7

A	x 12	B	x 8
	Ø6 x 20		8 x 30

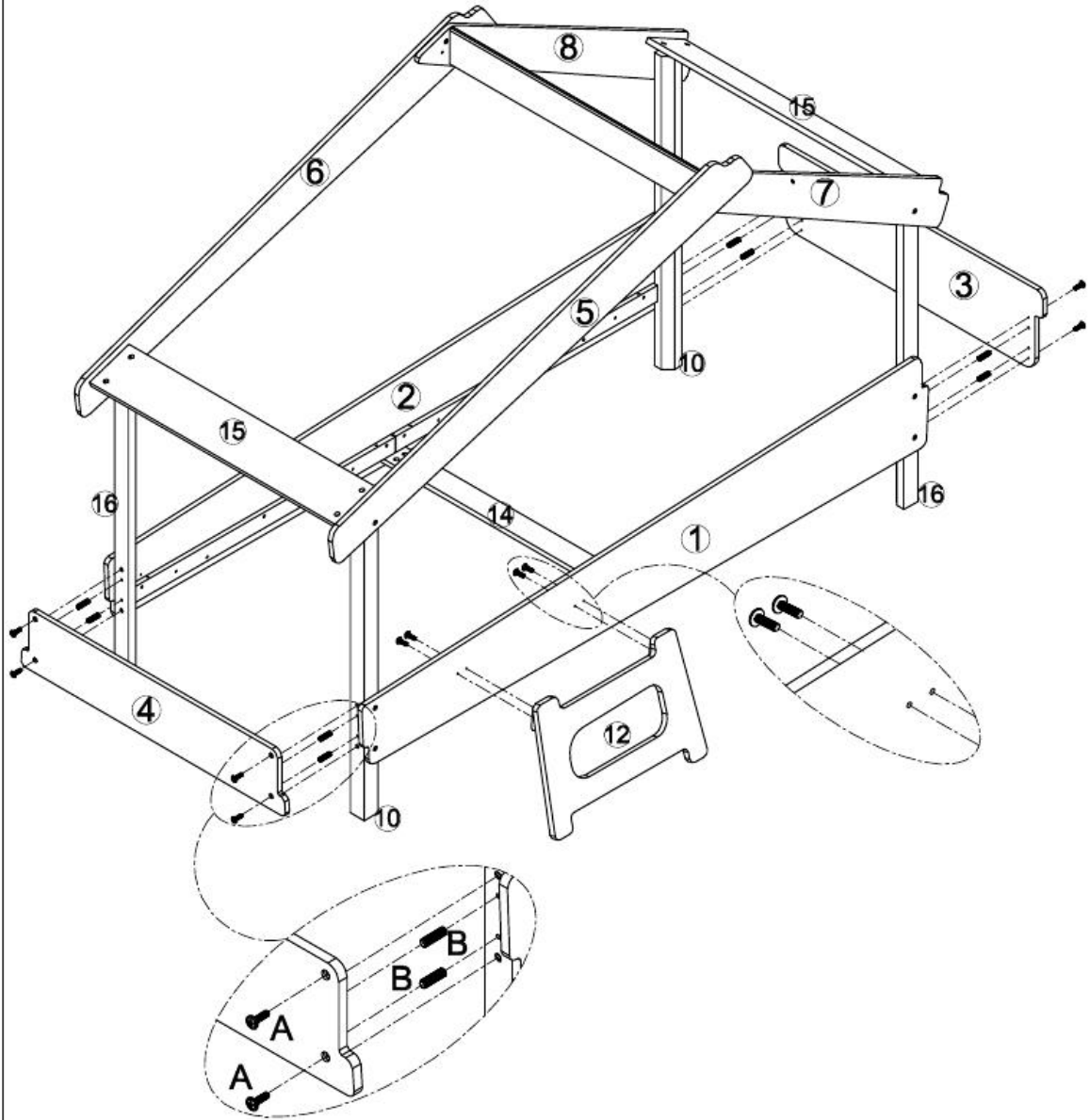

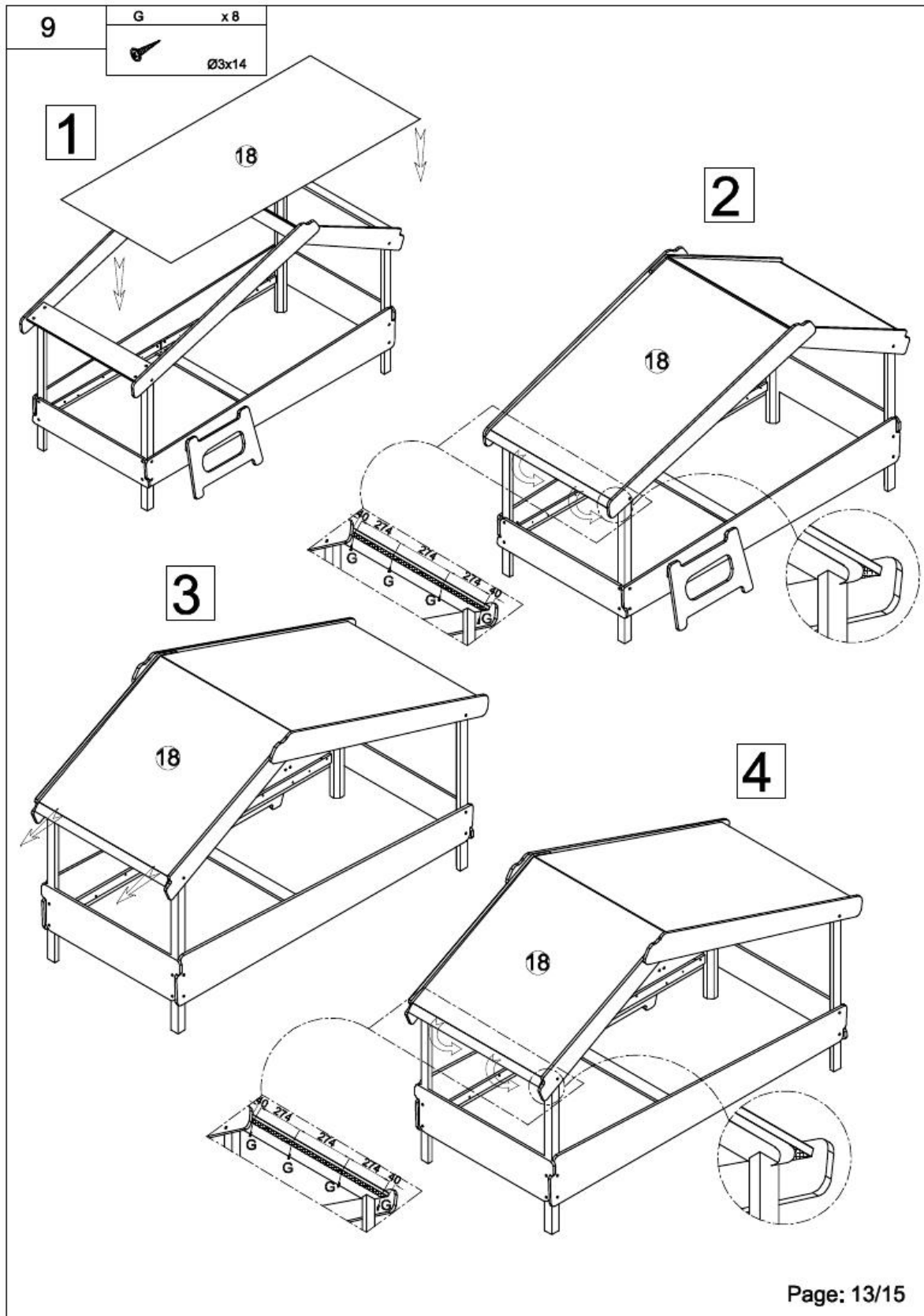

10

B x 12

