

- (PL)** Instrukcja montażu
- (CZ)** Návod k montáži
- (D)** Montageanleitung
- (GB)** Assembly instruction
- (F)** Model d'emploi
- (HU)** Szerelési útmutató
- (I)** Istruzione di montaggio
- (NL)** Handleiding voor de montage

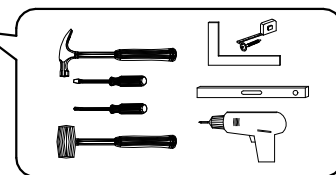

- (RU)** Инструкция по монтажу
- (RO)** Instrucțiuni de montare
- (SK)** Návod k montáži
- (TR)** Montaj talimatı

⚠ Uwaga • Upozornění • Achtung • Attention • Caution • Figyelem ⚠ Attenzione • Opgelet • Внимание • Atenție • Upozornenie • Dikkat ⚠	
PL	Czyszczenie należy wykonać wyłącznie za pomocą ściereczki lub lekko nawilżonego ręcznika. Nie stosować środków czyszczących do szorowania.
CZ	Čistění je nutné vykonávat výhradně pomocí utěrky nebo lehce navlhčeného ručníku. Nepoužívejte čisticí prostředky obsahující abrazivní částice.
D	Bitte nur mit einem Staubtuch oder leicht feuchtem Lappen reinigen. Keine scheuernden Putzmittel verwenden.
GB	Please only clean with a duster or a damp cloth. Do not use any abrasive cleaners.
F	Le nettoyage se fait uniquement à l'aide d'un torchon ou d'une serviette légèrement mouillée.
HU	A tisztítás kizárólag törölruha vagy enyhén nedvesített törölköző segítségével végezhető. Súroló hatású tisztítószerket nem szabad használni.
I	Pulire esclusivamente con un panno o un asciugamano umido.
NL	Reinig alleen met een stofdoek of een lichtjes vochtige doek. Gebruik geen schurende poetsmiddelen.
RU	Очищайте от пыли тряпкой или слегка влажной ветошью. Не допускается применение чистящих средств, не пред-назначенных для ухода за мебелью.
RO	Curățarea trebuie efectuată numai cu o cârpă sau cu un prosop ușor umezit. Nu utilizați agenți de curățare abrazivi.
SK	Čistení je nutné vykonávat výhradně pomocí utierky nebo ľahko zvlhnutým ručníkom. Nepoužívajte čistiace prostriedky obsahujúce abrazívni častice.
TR	Lütfen sadece bir toz bezilye veya hafif nemli yumuşak bir bezle siliniz. Aşındırıcı temizlik malzemeleri kullanmayınız.

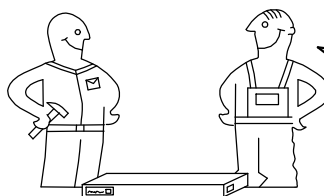
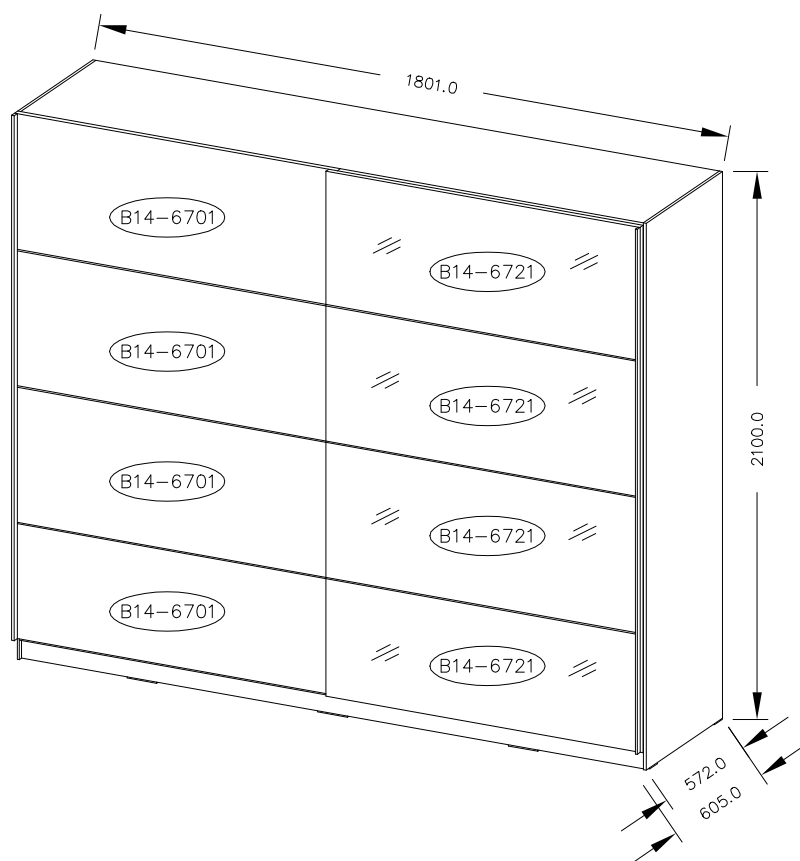
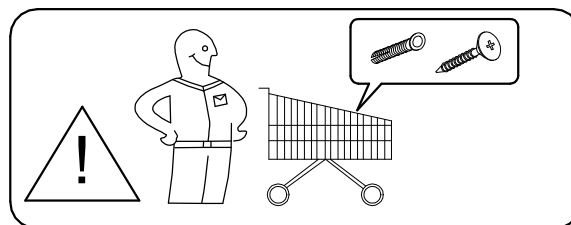
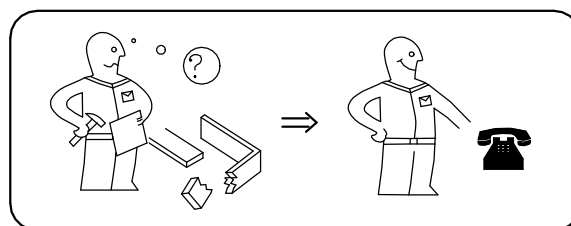
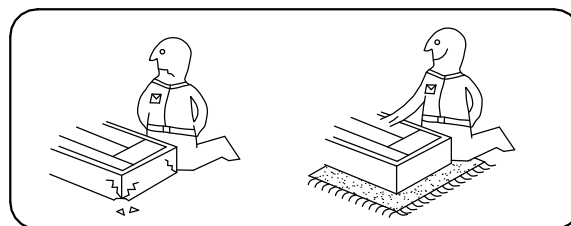



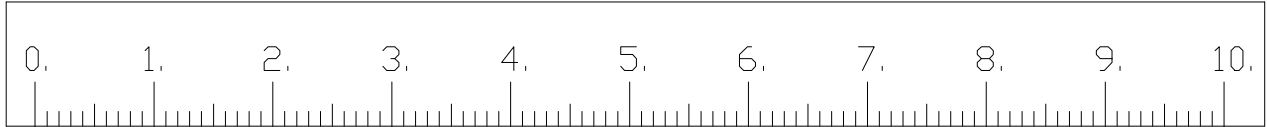
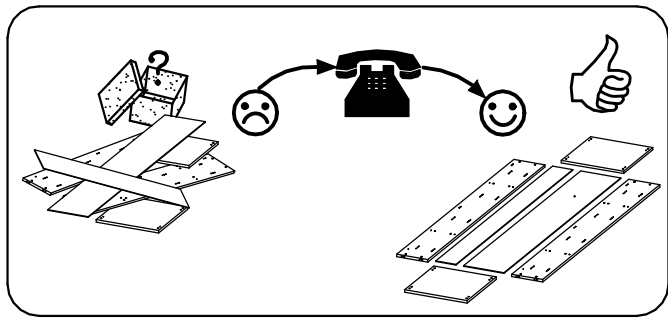
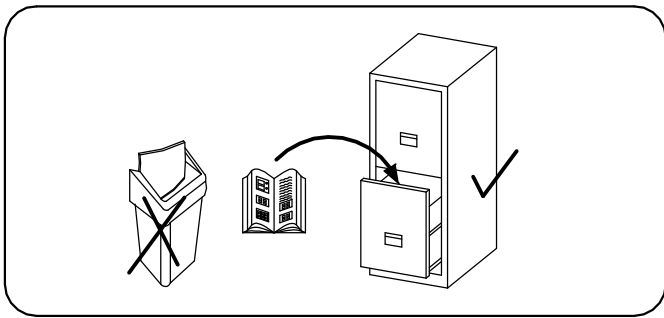



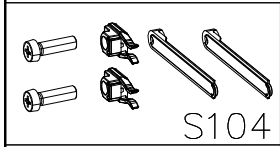
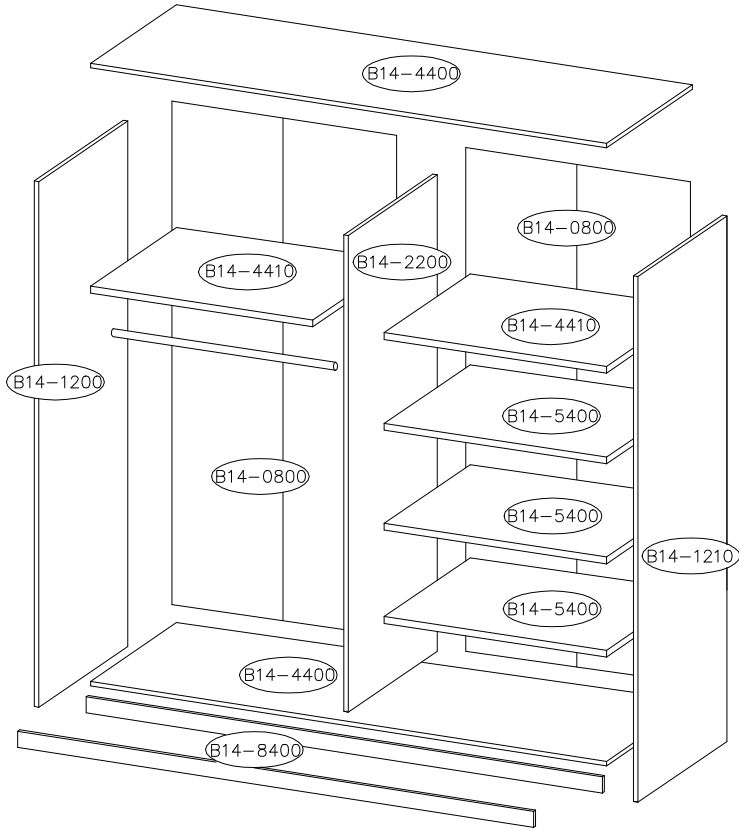

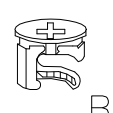
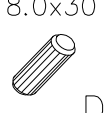

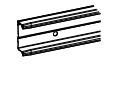
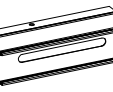



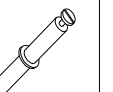
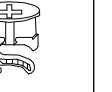
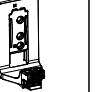
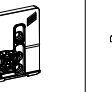

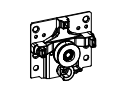

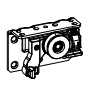
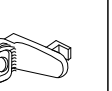
BETA 22.97/FO/OF/WO/KL16.56

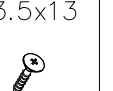

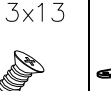
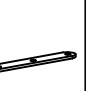

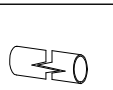
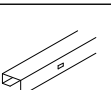
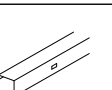
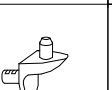
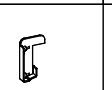
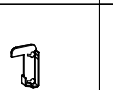
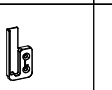
MAX 5kg
 B14-4410 B14-5400



1 KPL		
		
16	12	16
8.0x30		



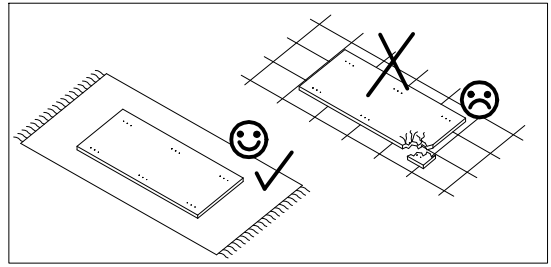

										
S90	S91	W	H	W3	W1	A4	B2	S143	S142	P2
1	1	10	2	2	5	2	8	2	2	10
										
S92	S93	S94	S95	J1	D2	W8	J2	F	J16	F2
1	1	1	1	12	2	56	2	24	6	12
										
G7	H1	S19	S18	E2	S99	S100	S101	S102	J6	J
32	1	2	2	12	1	1	1	1	8	12

		3.5x13
P2	J6	W8
6	8	32

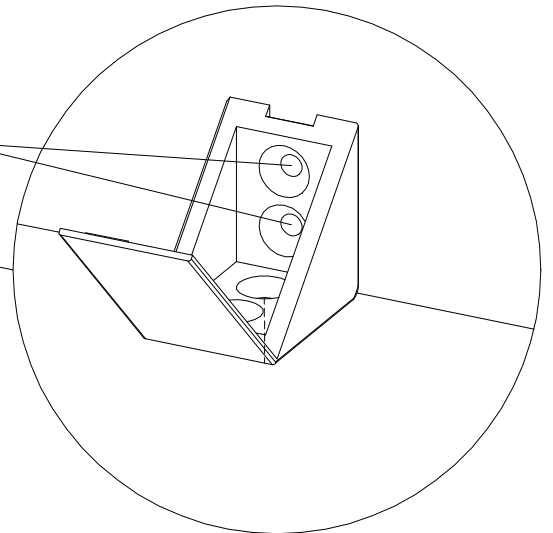
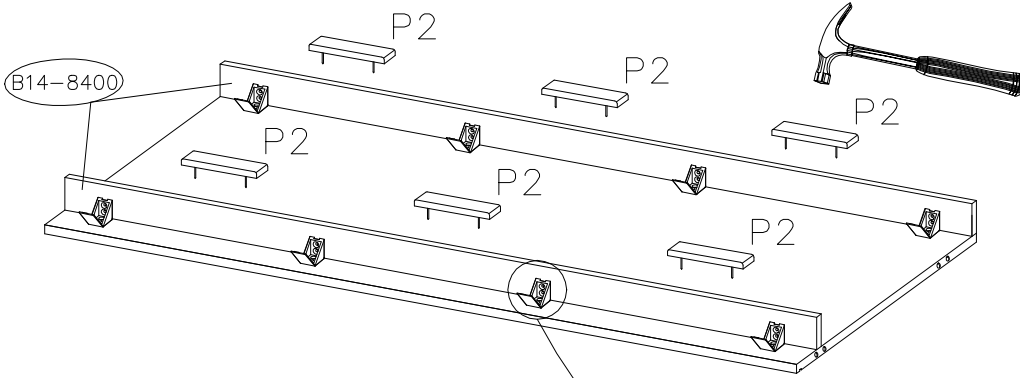
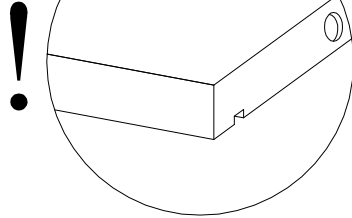
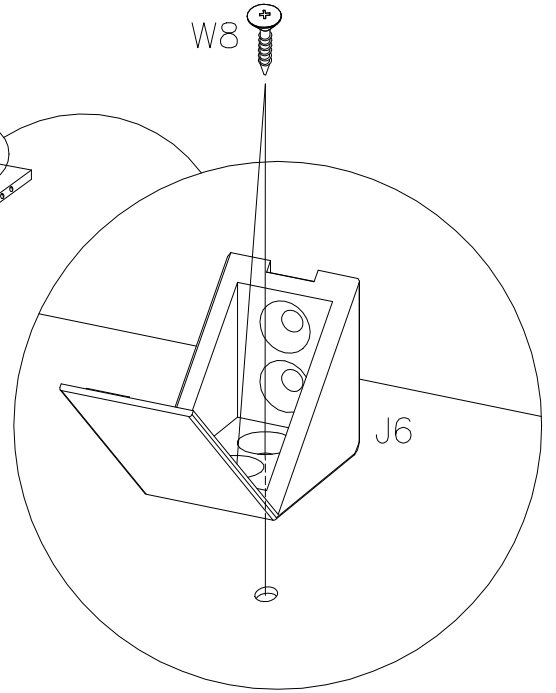





1x

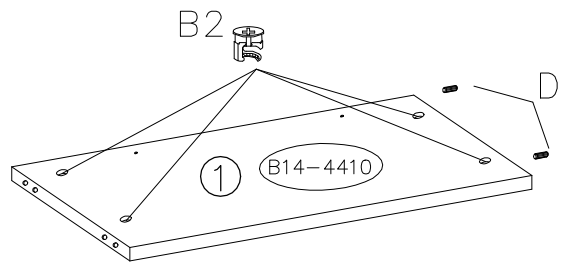
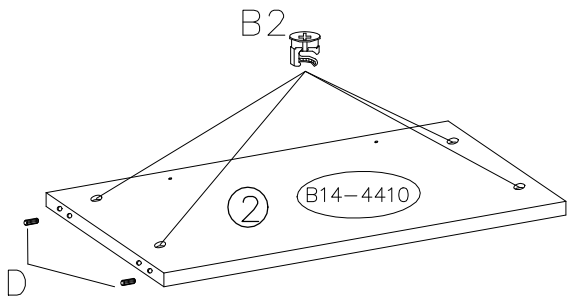
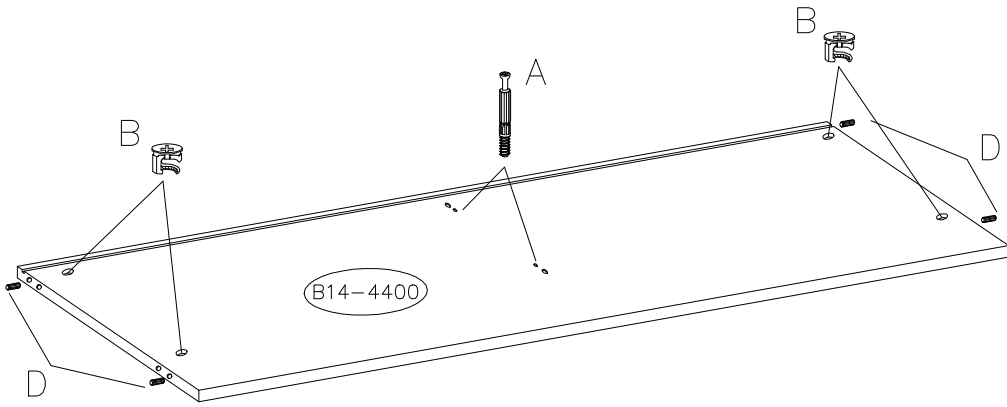
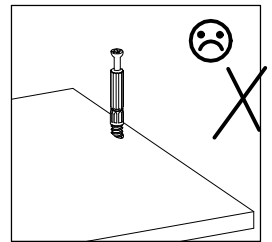
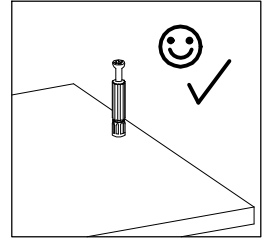
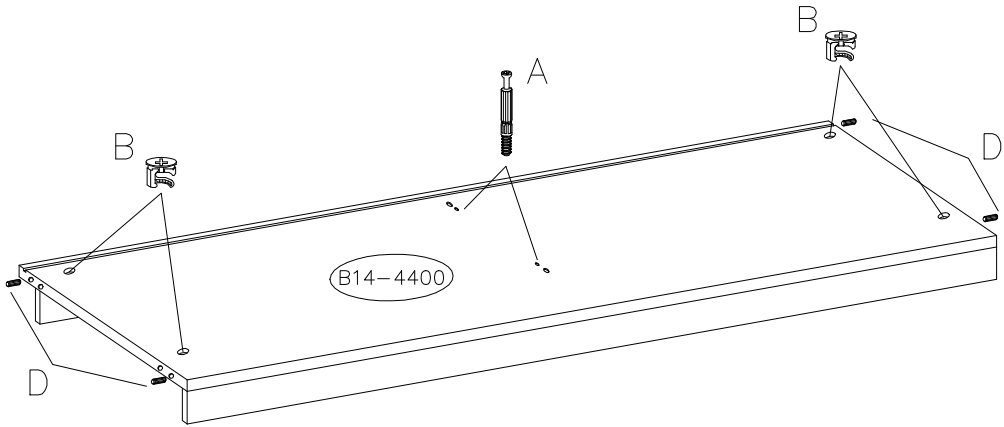



 A	 B	8.0x30  D	 B2
4	8	12	8

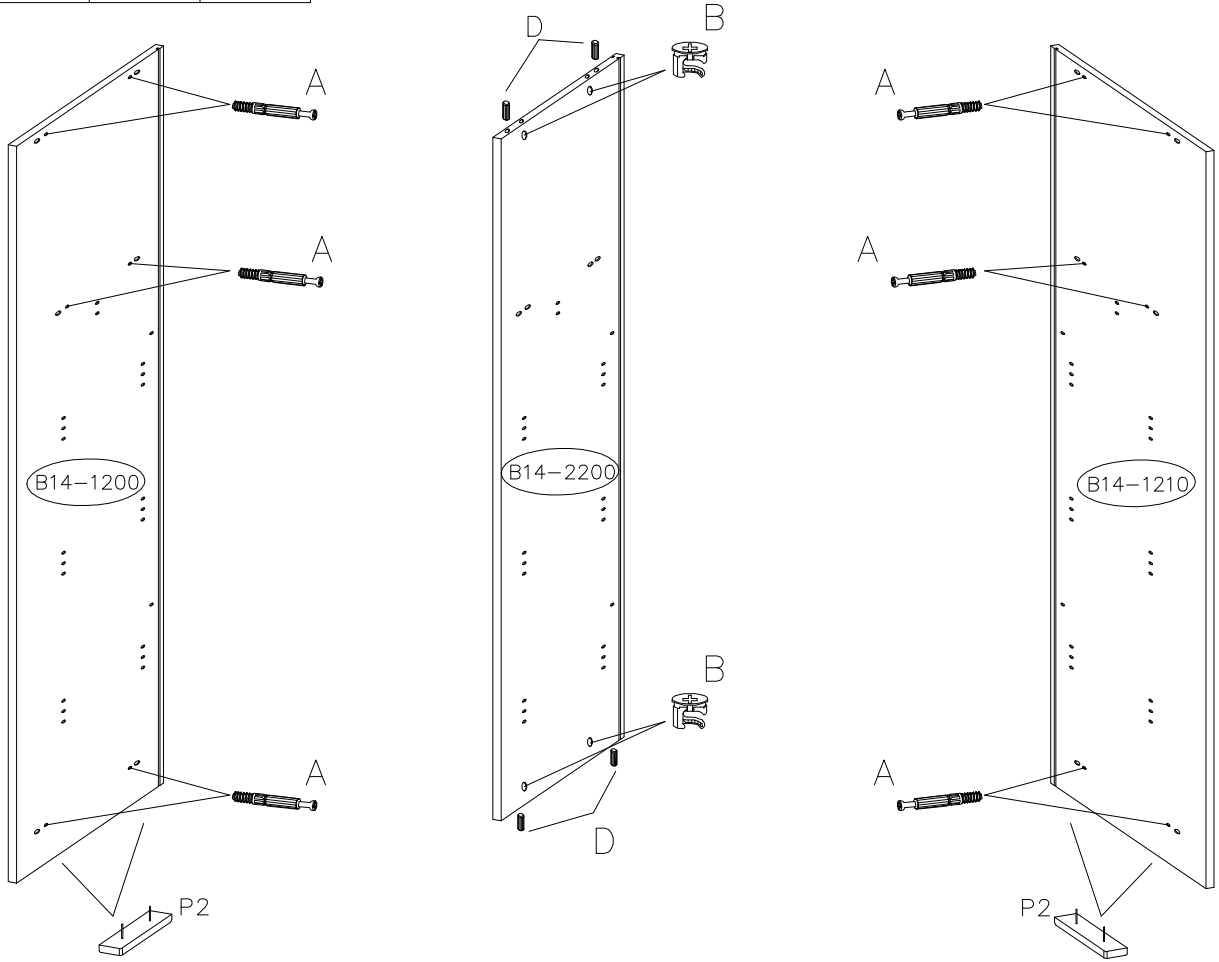

			
A	B	D	P2
12	4	4	4



	
J1	F2
2	2

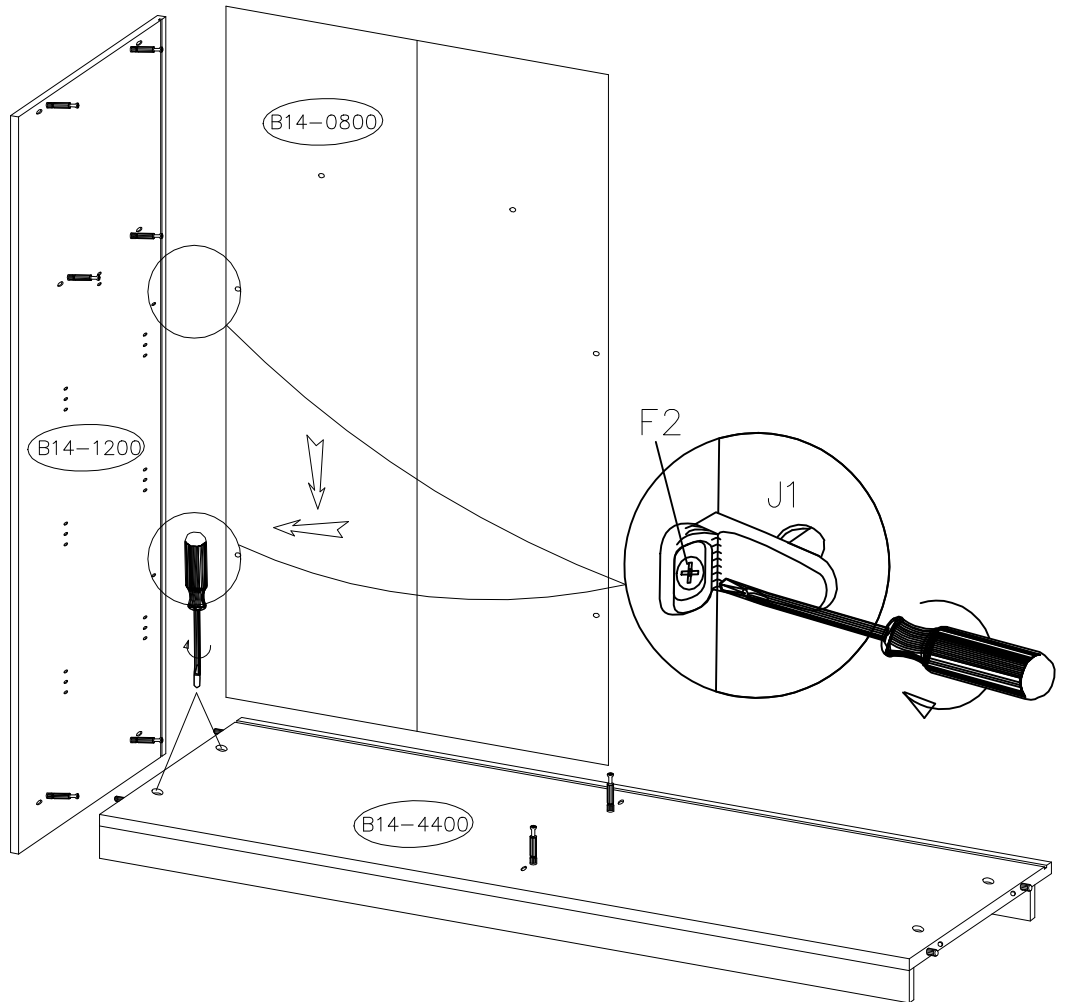

	6.3x11
J1	F2
2	2

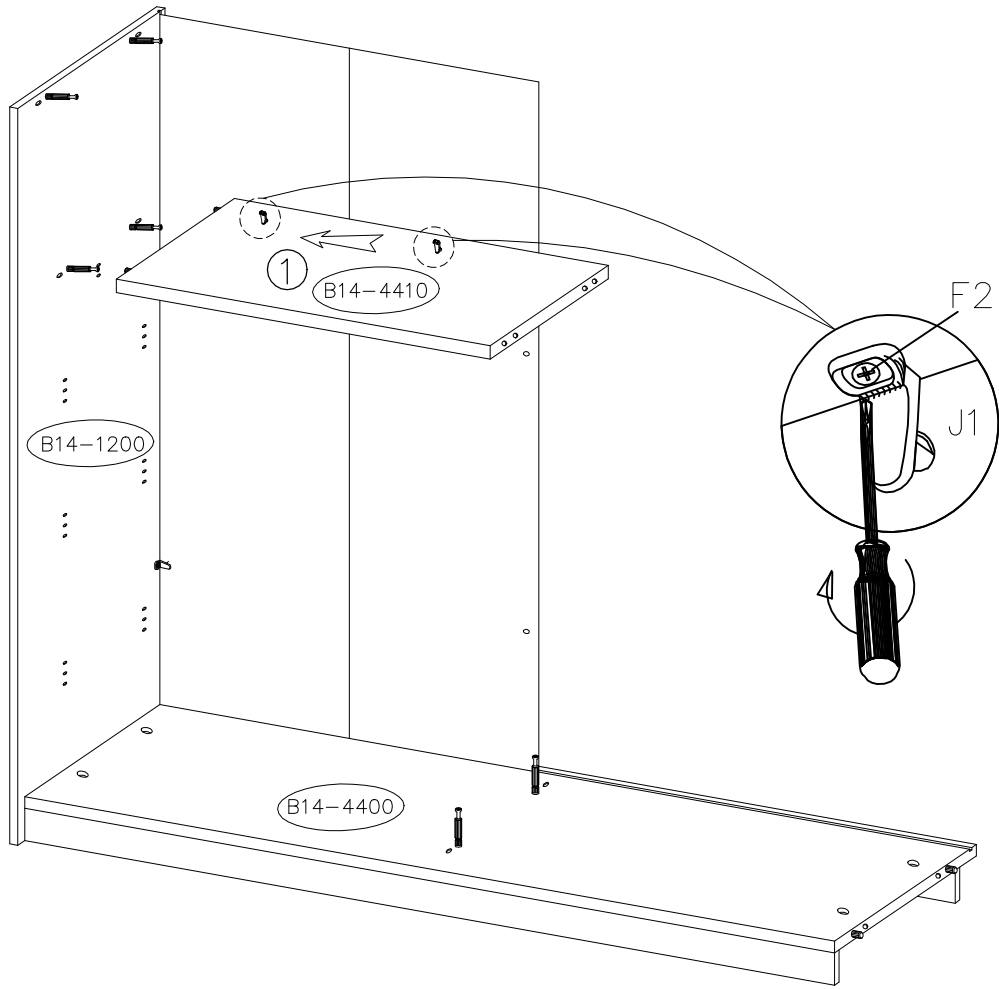

	6.3x11
J1	F2
2	2

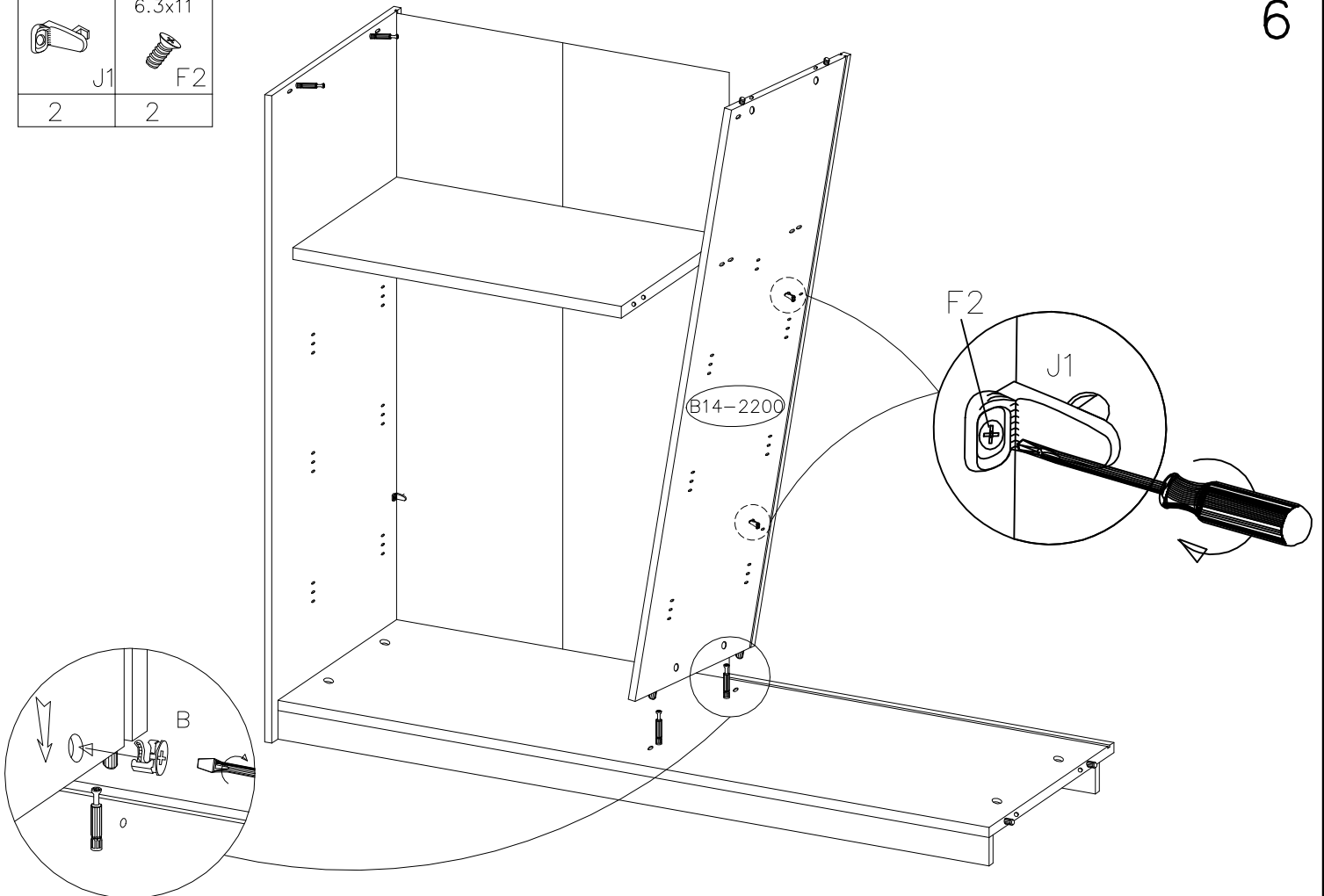

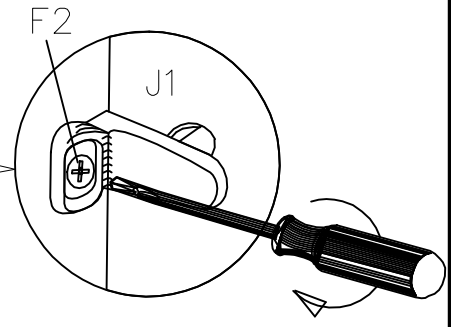
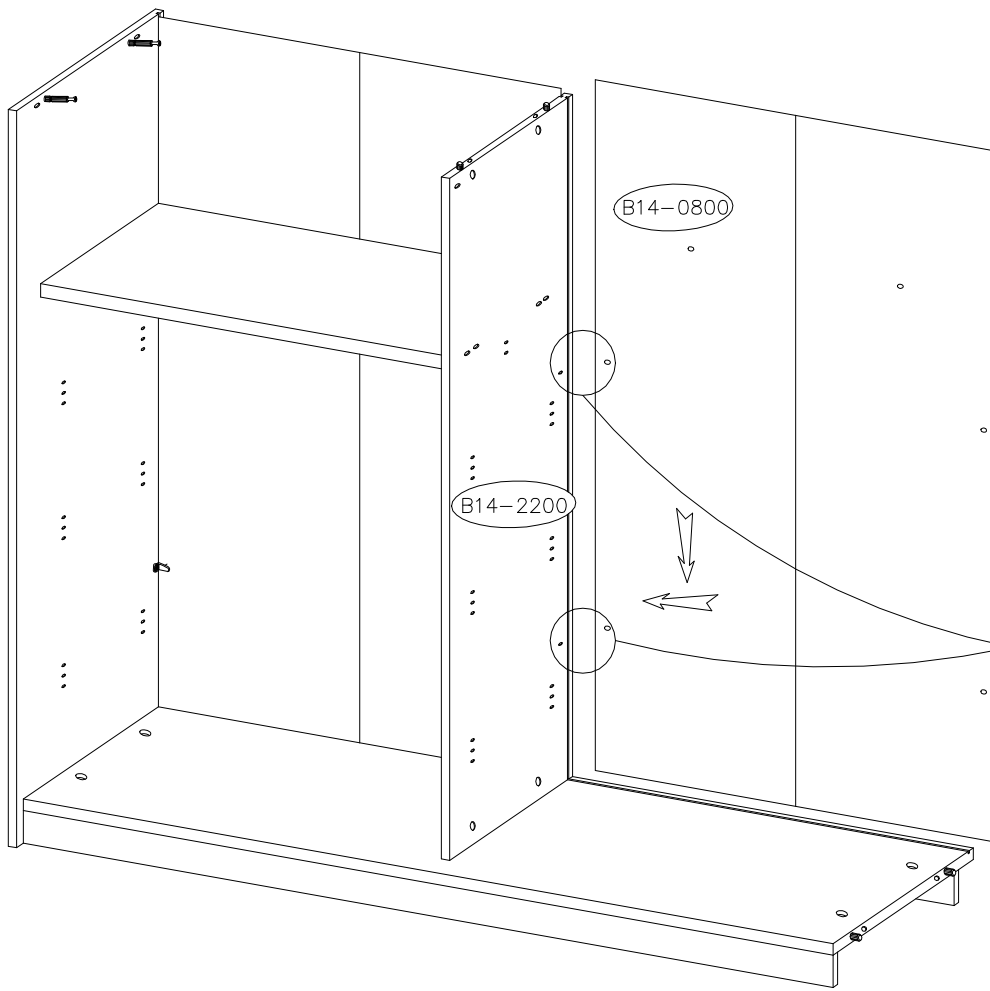

7

	6.3x11
J1	F2
2	2



8

	6.3x11
J1	F2
2	2
	
A4	
2	
	8.0x50
D2	
2	

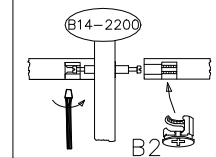
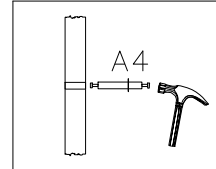
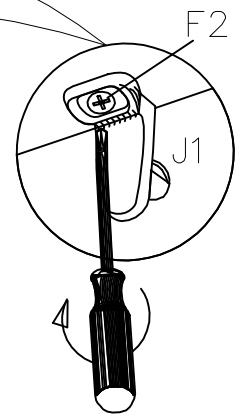
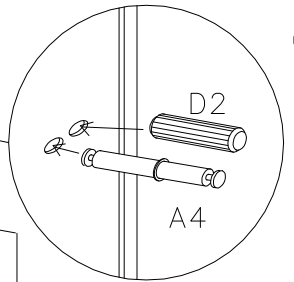
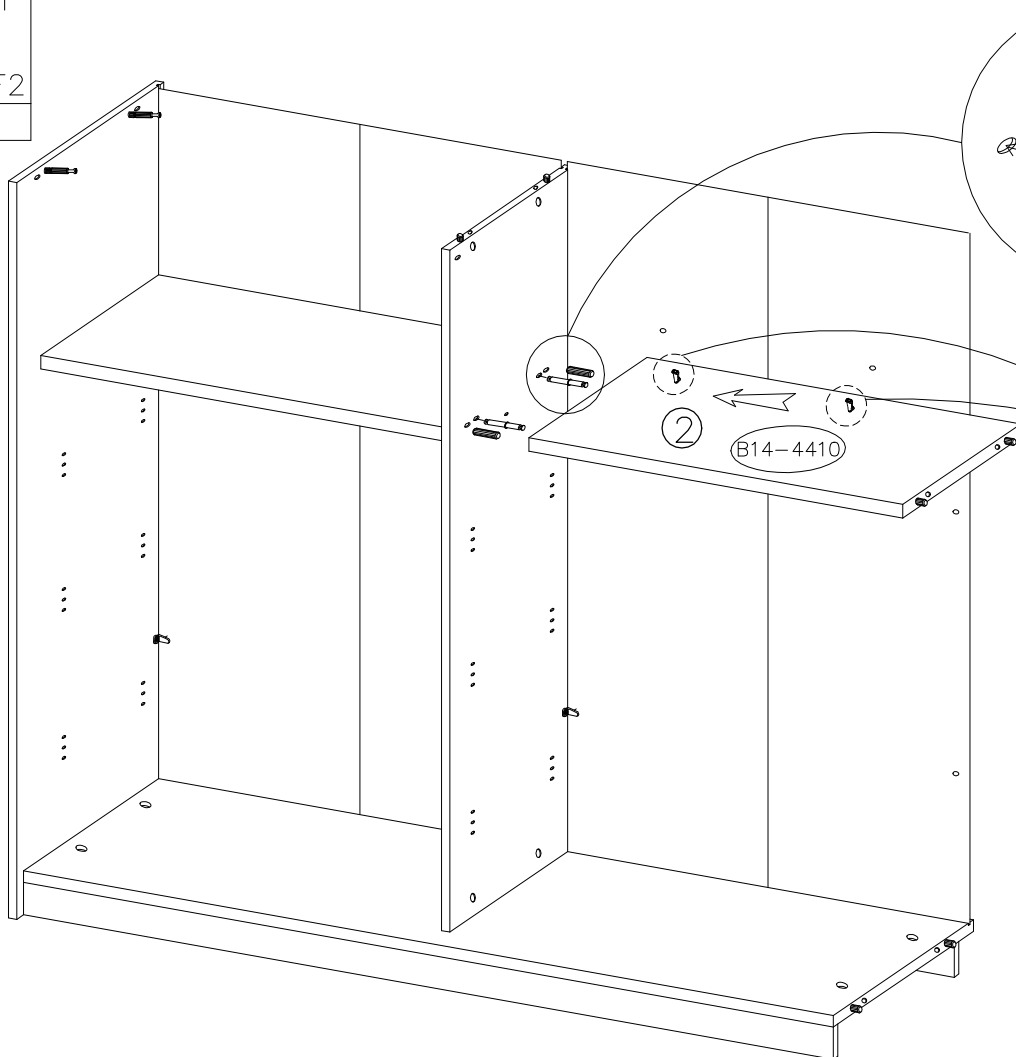

9

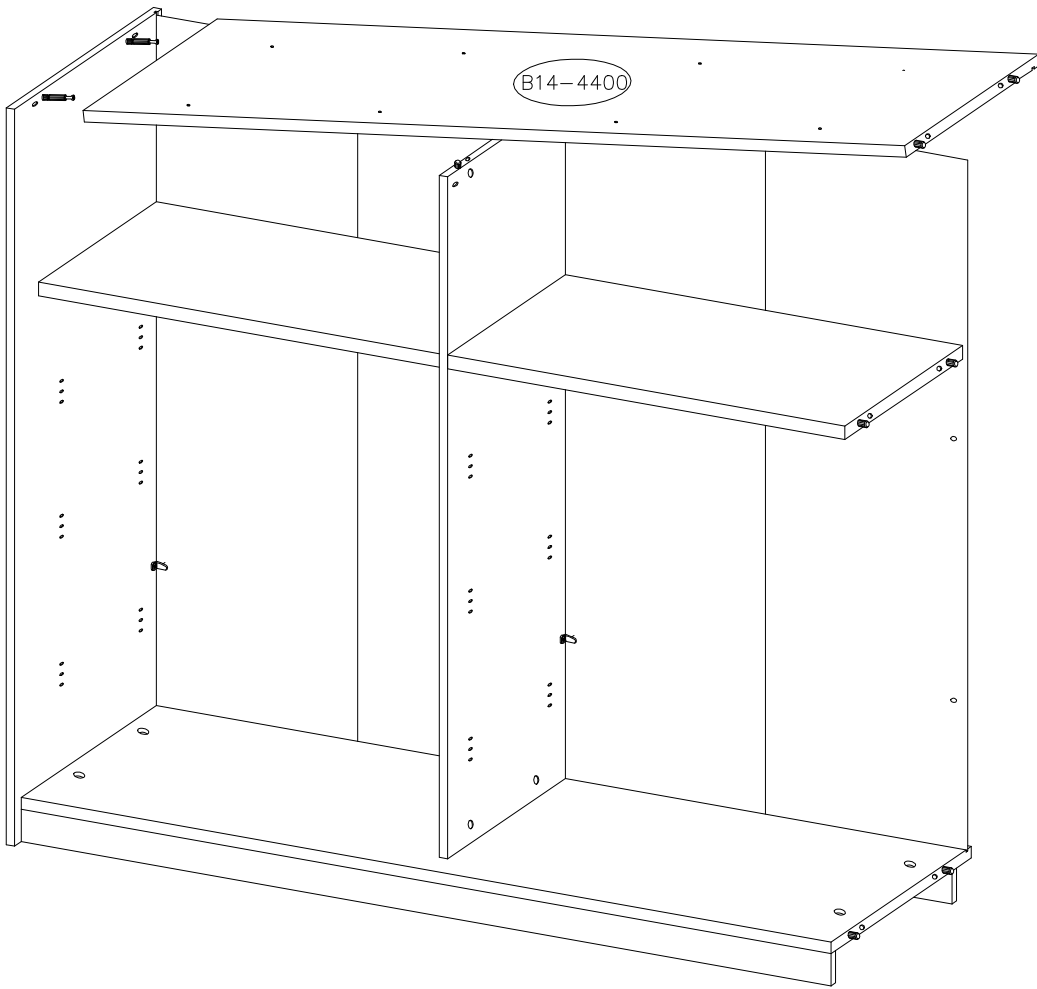

10

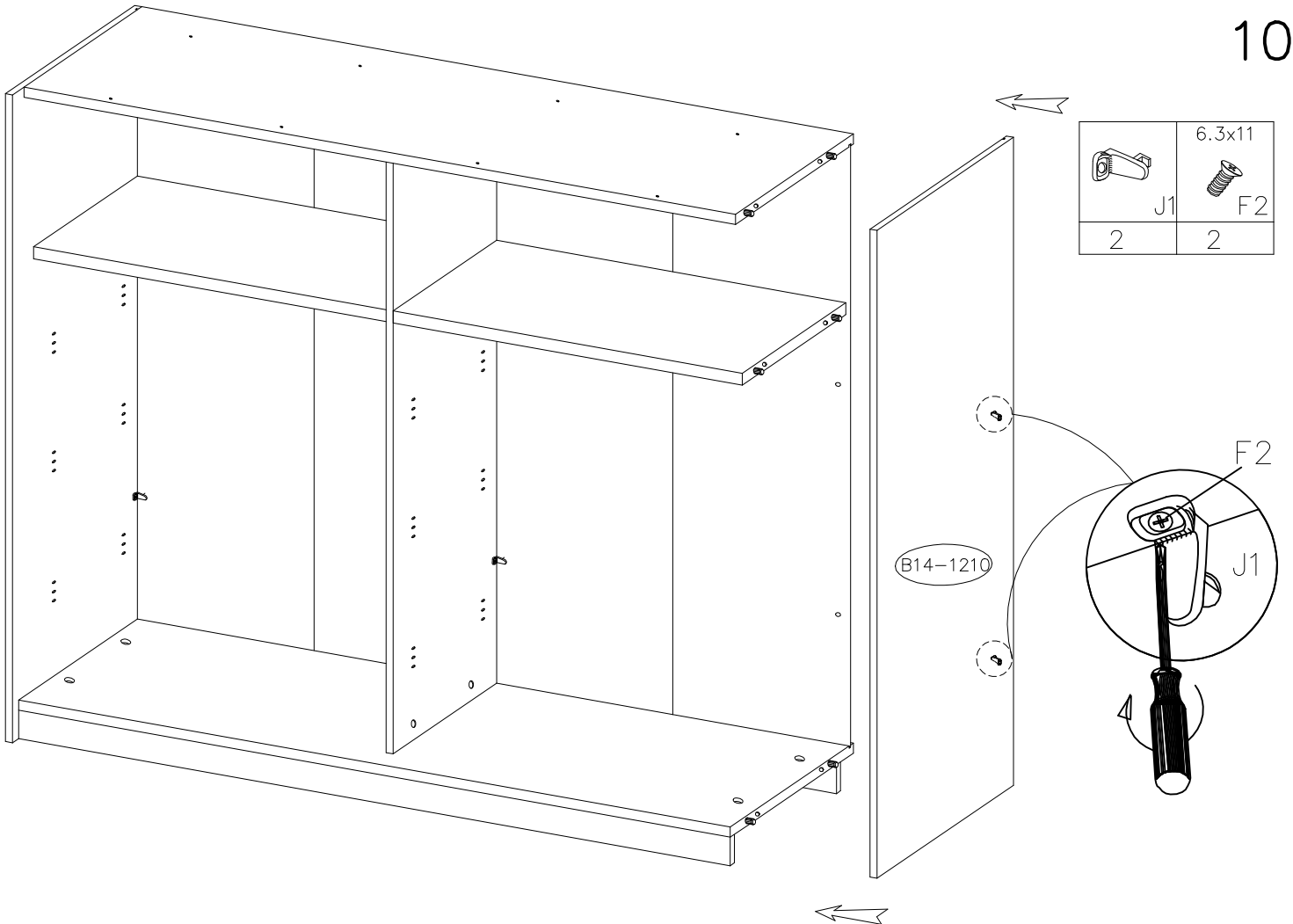

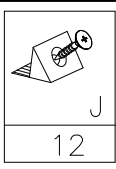

11

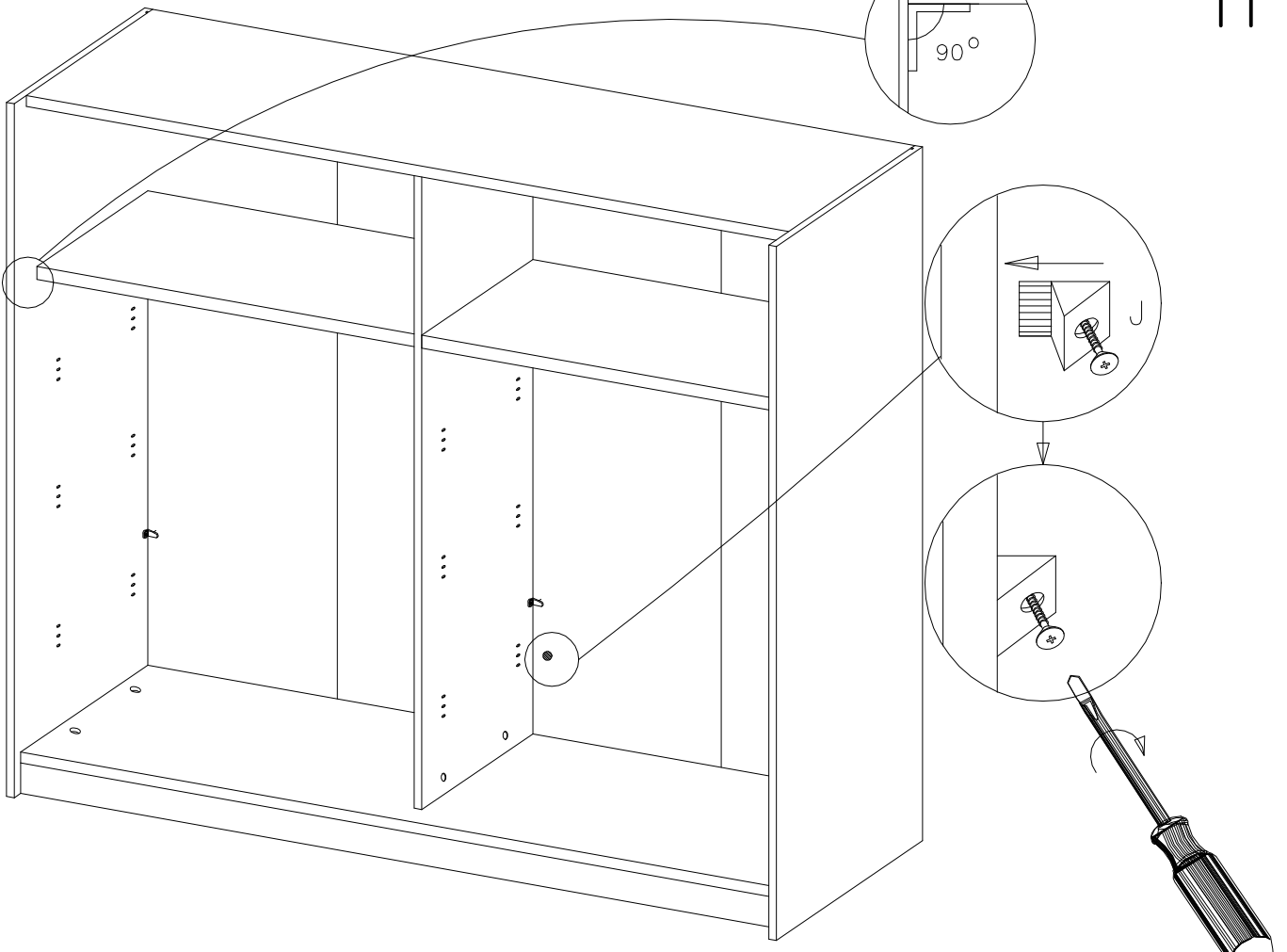

	3.0x13	
H		W3
2	2	1
E2		
12		

12

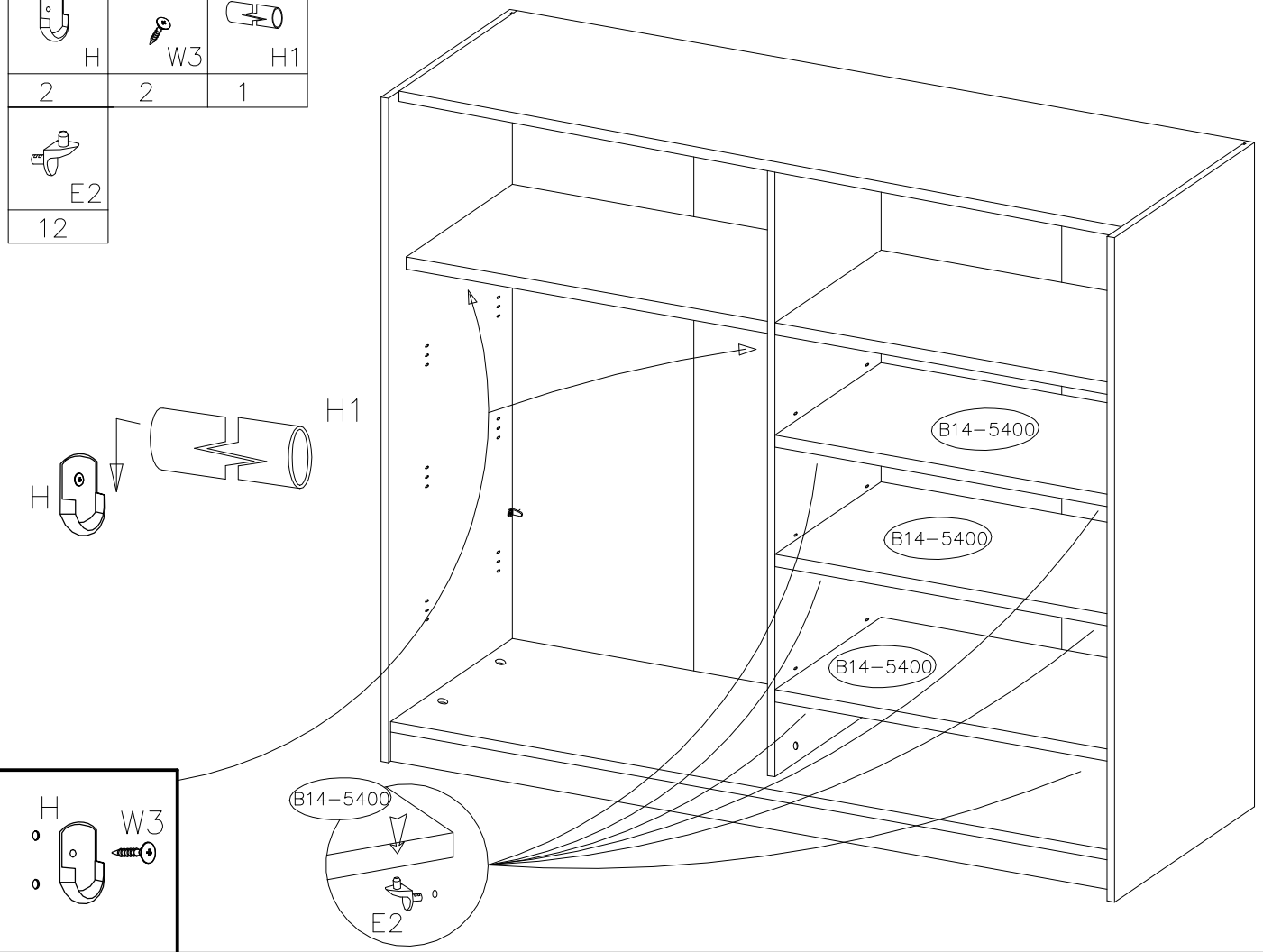

3.5x16



W



S101



S102

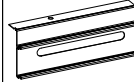

S91

10

1

1

1

13

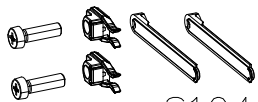
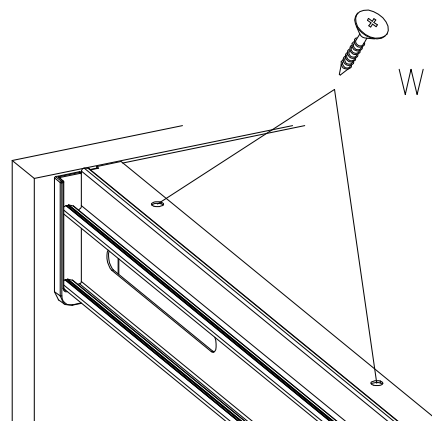
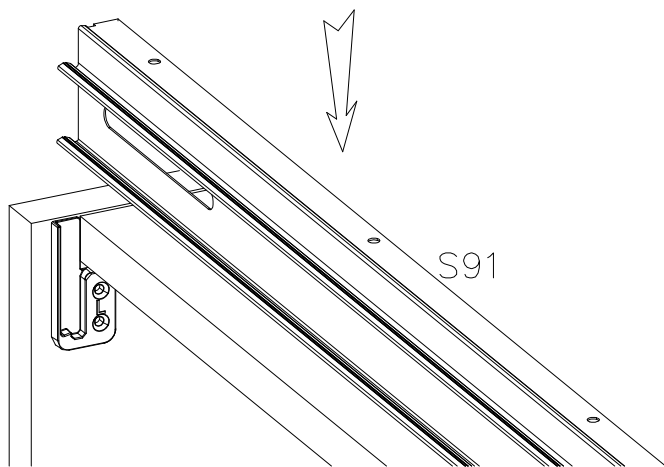
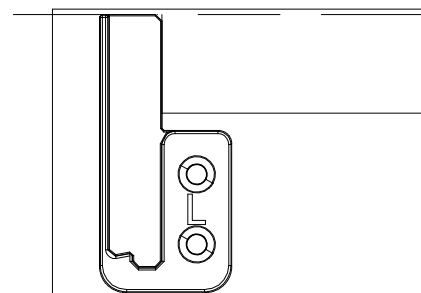
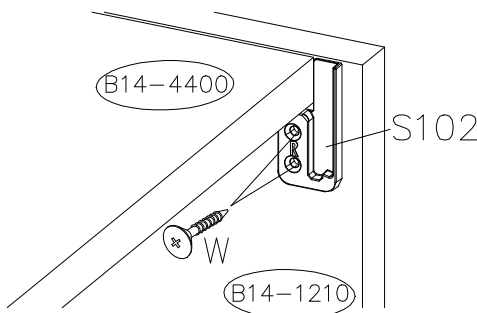
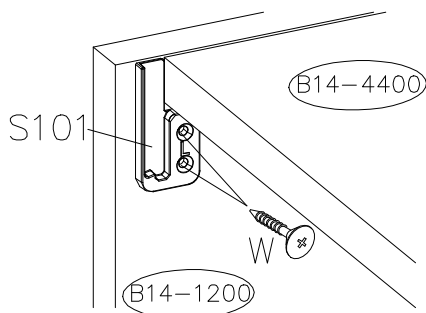



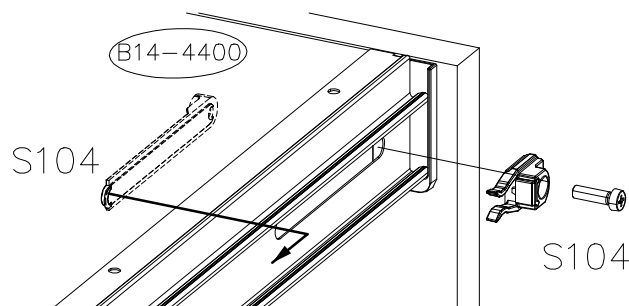
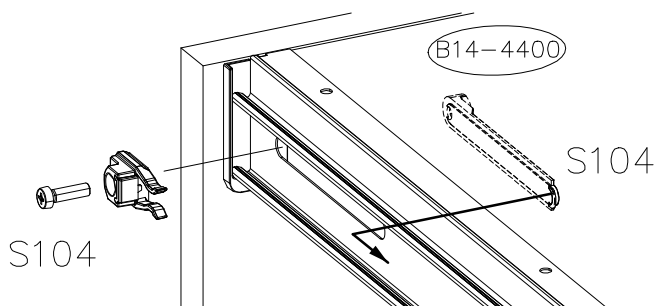

S104

1 KPL

14



 W1	 S99	 S100	 S90
5	1	1	1

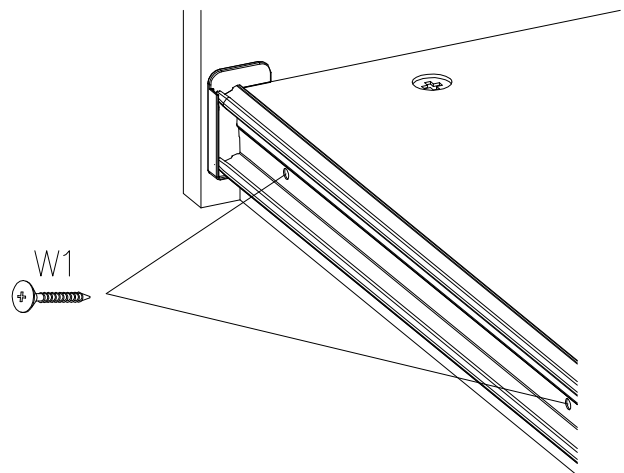
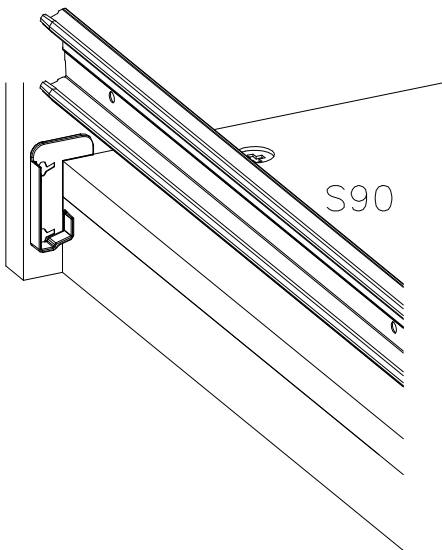
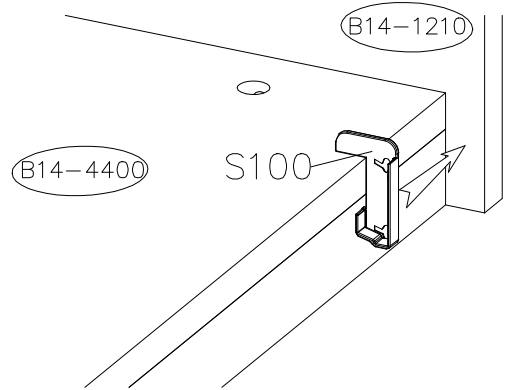
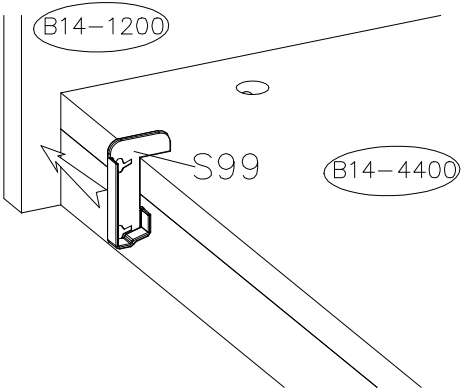
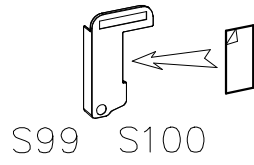

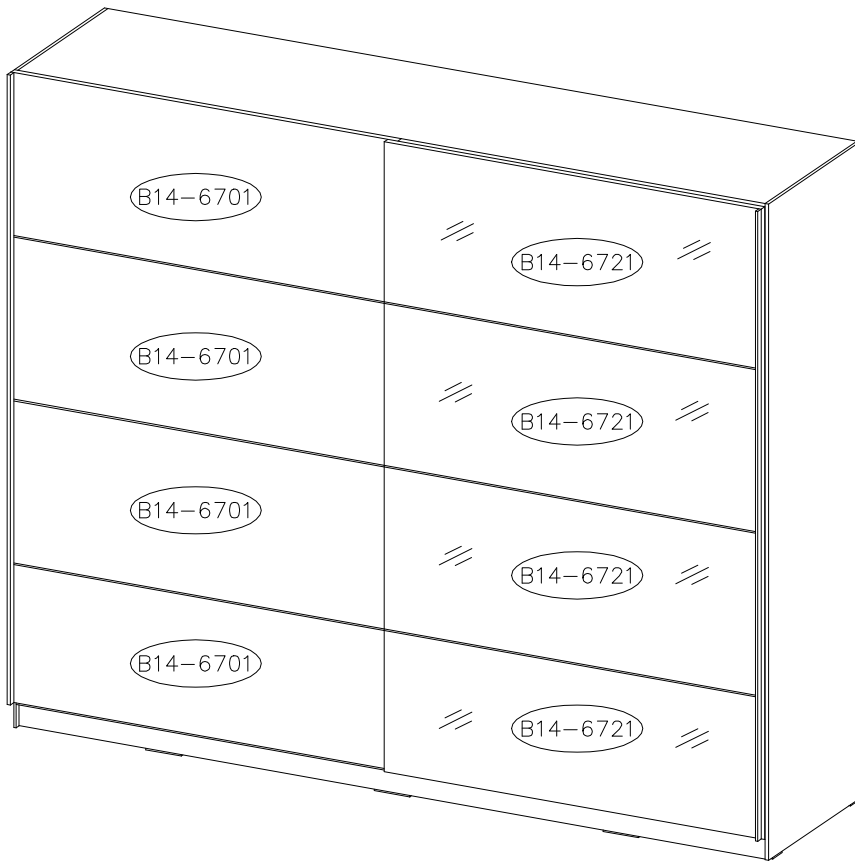

a



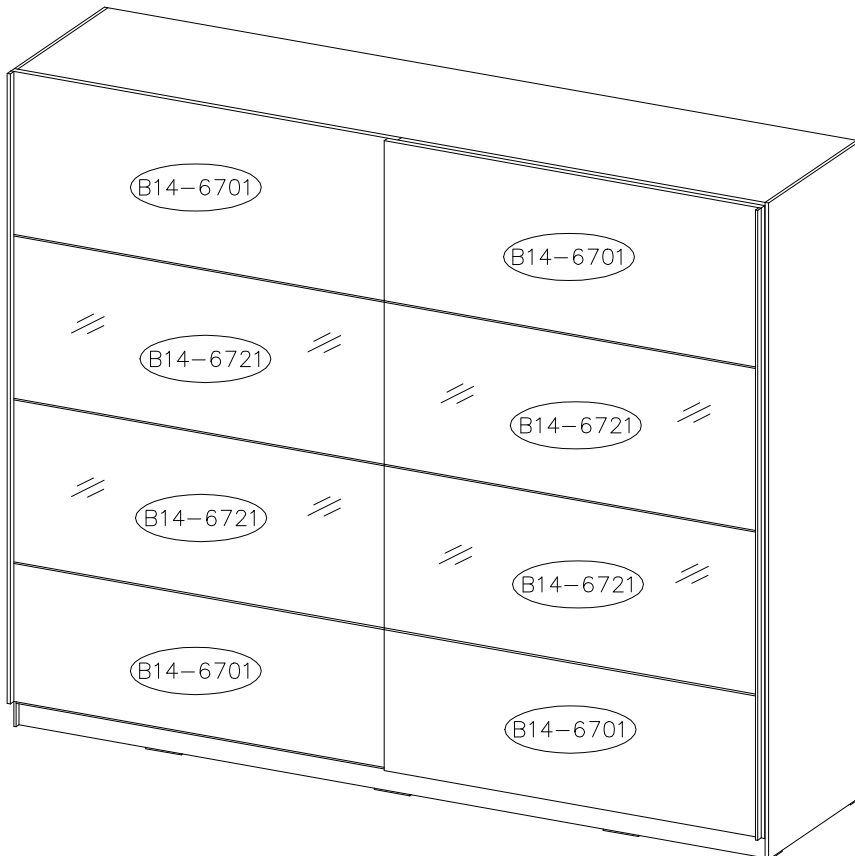



b

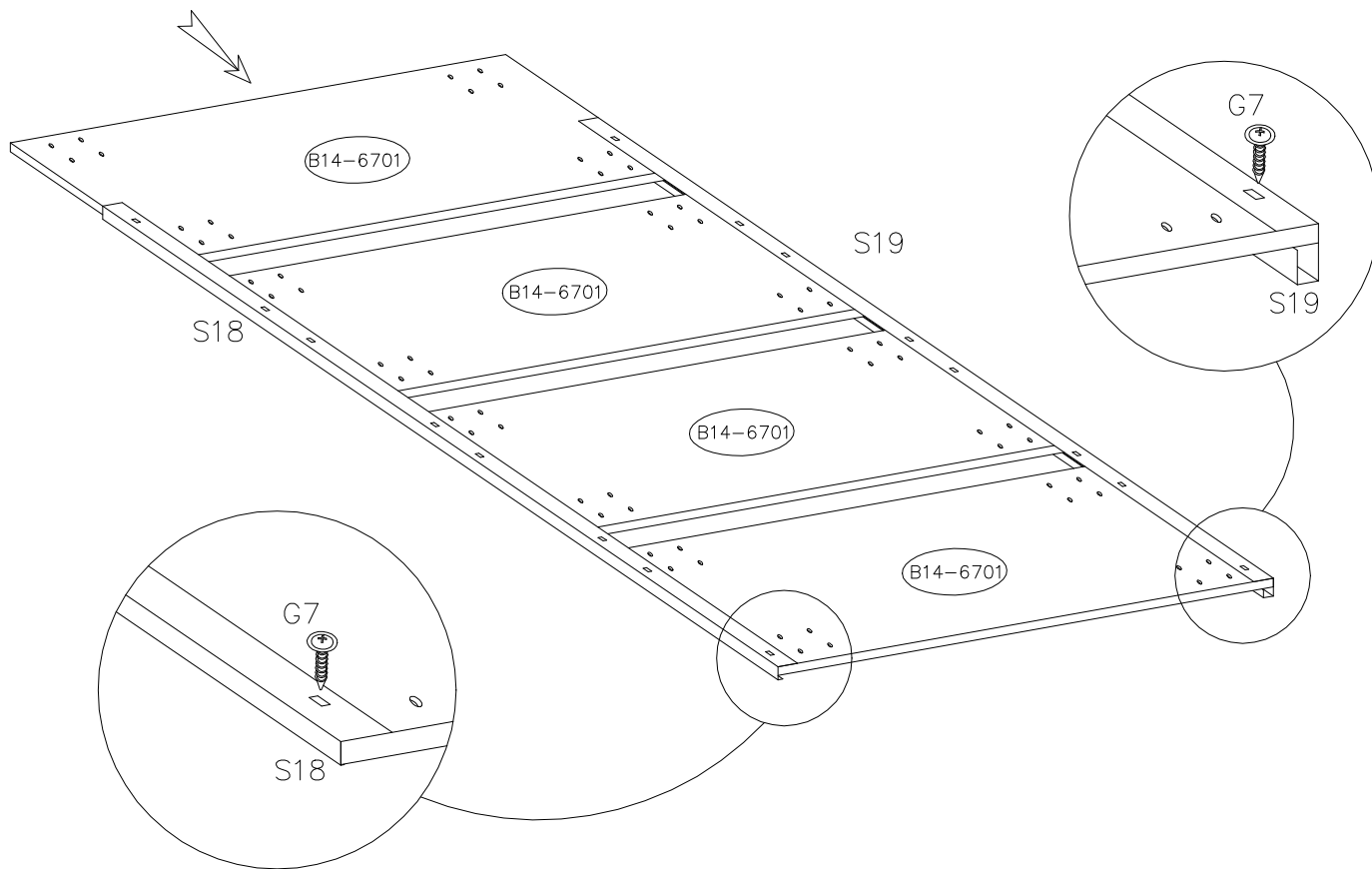

3.5x13  G7	 S19	 S18
16	1	1

16a



3.5x13  G7	 S19	 S18
16	1	1

17a

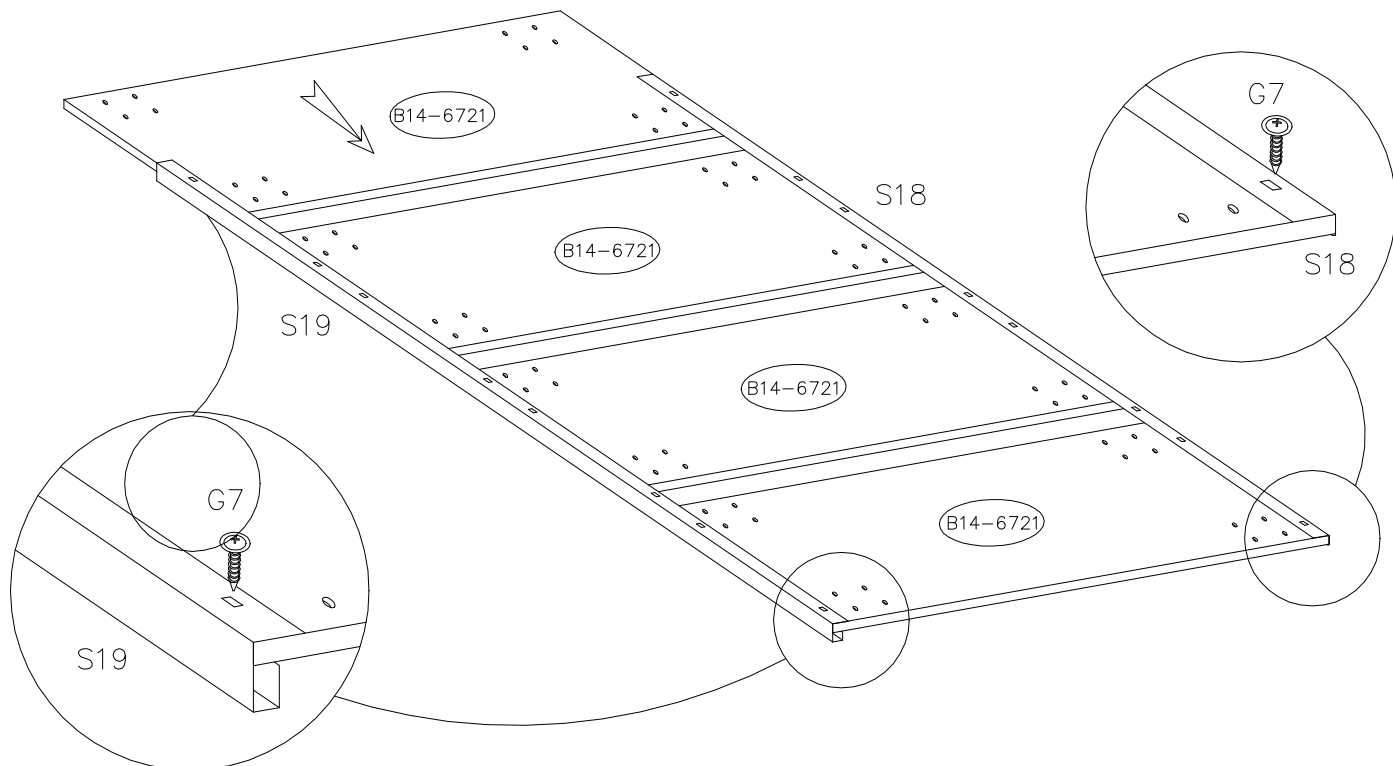

3.5x13	
W8	J16
12	3

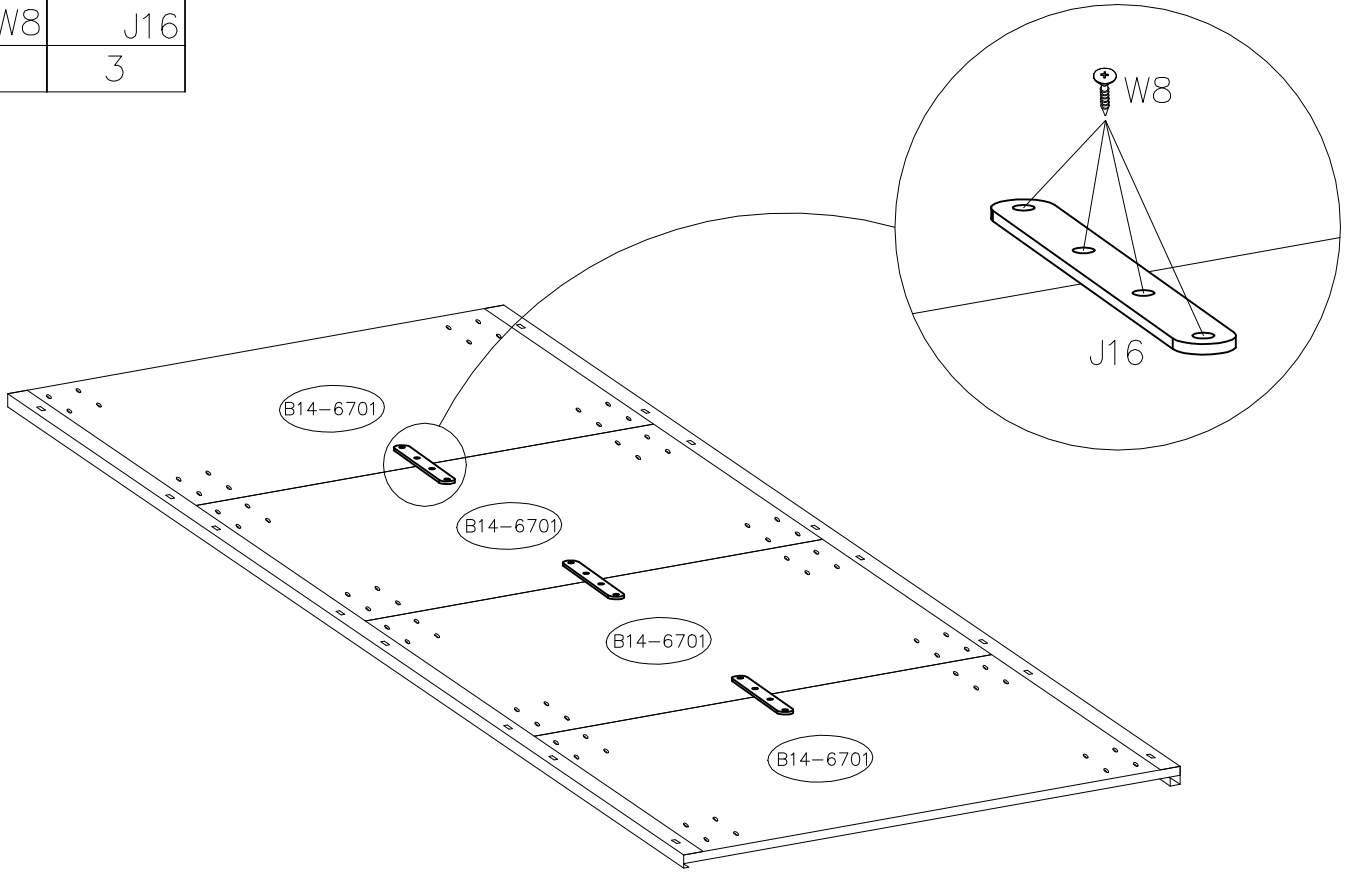

18a





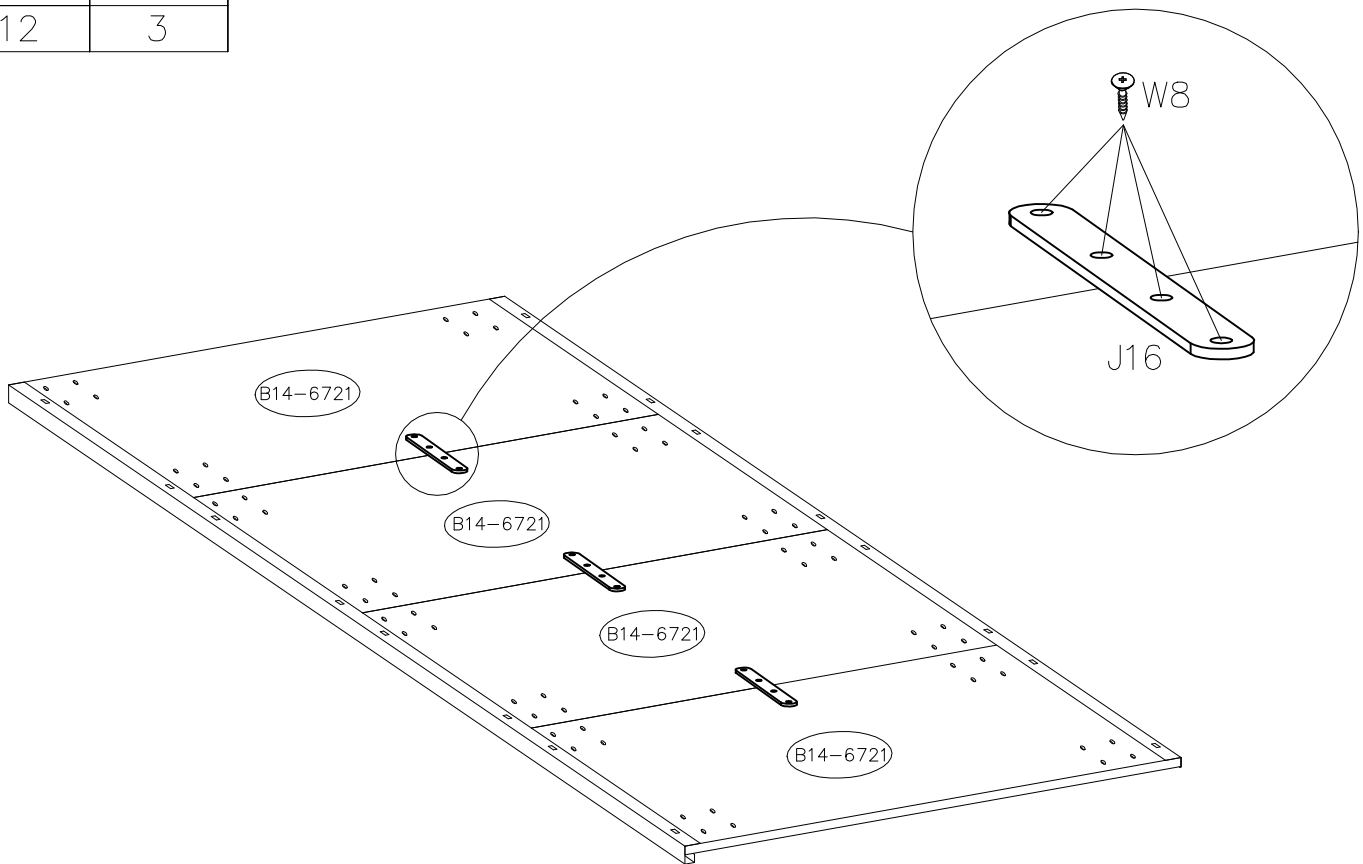

3.5x13	
W8	J16
12	3

19a

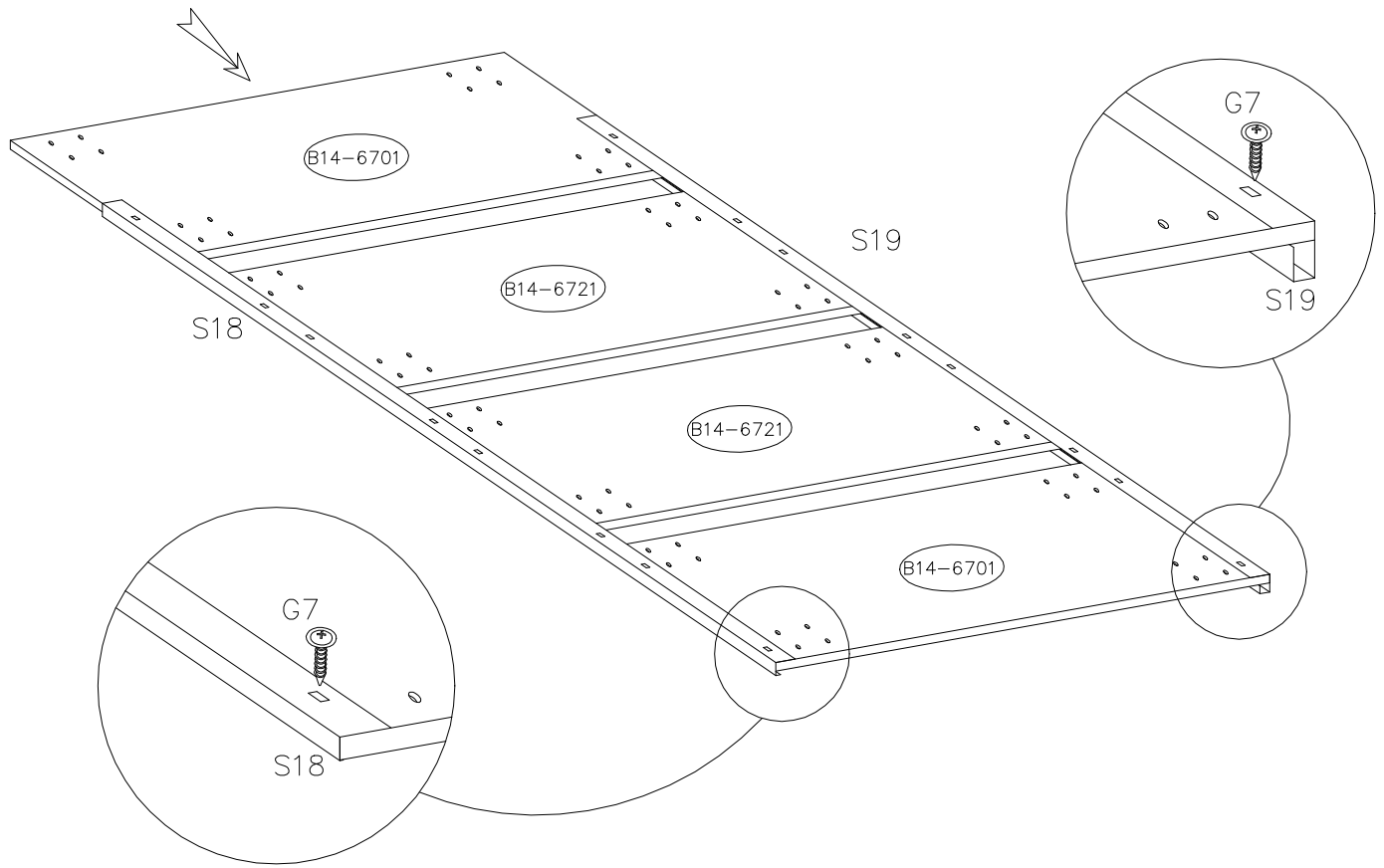

3.5x13			
	G7	S19	S18
16		1	1



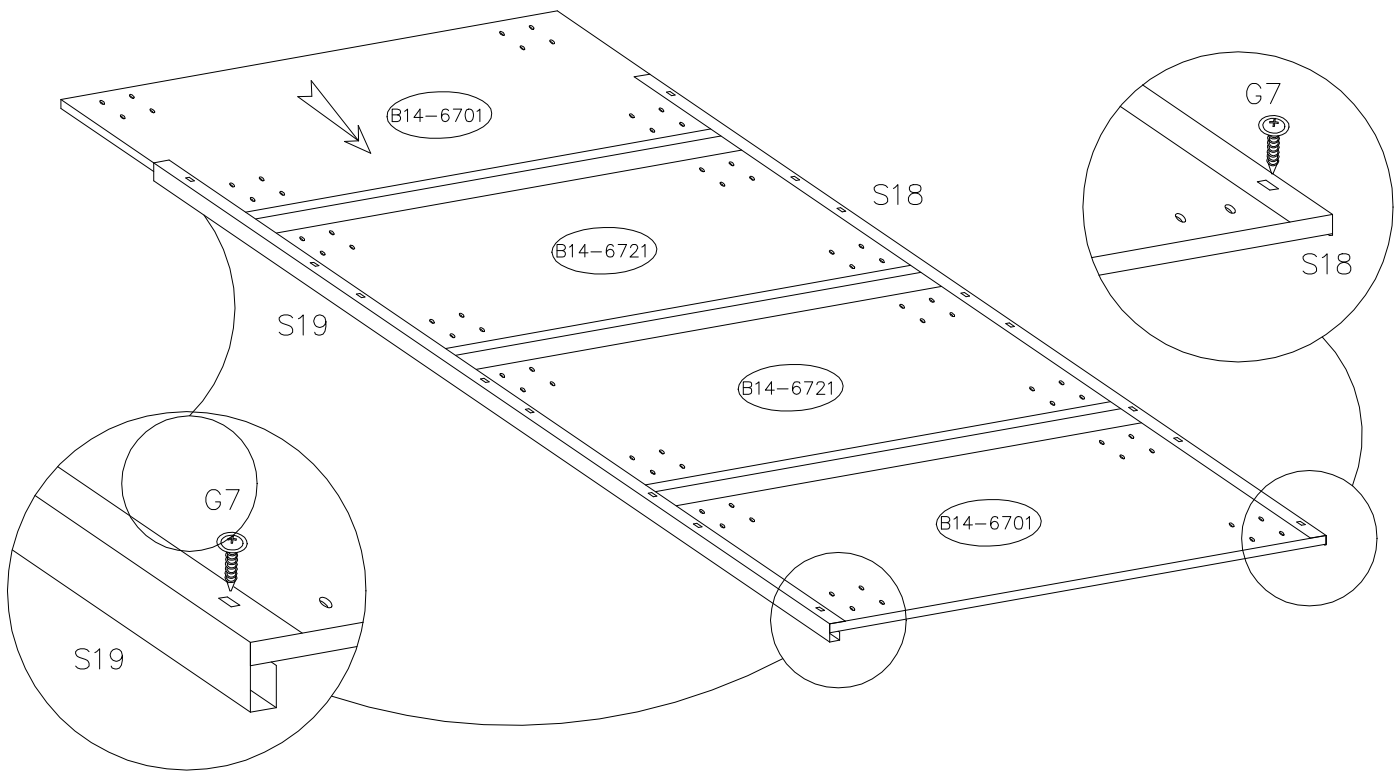

3.5x13			
	G7	S19	S18
16		1	1

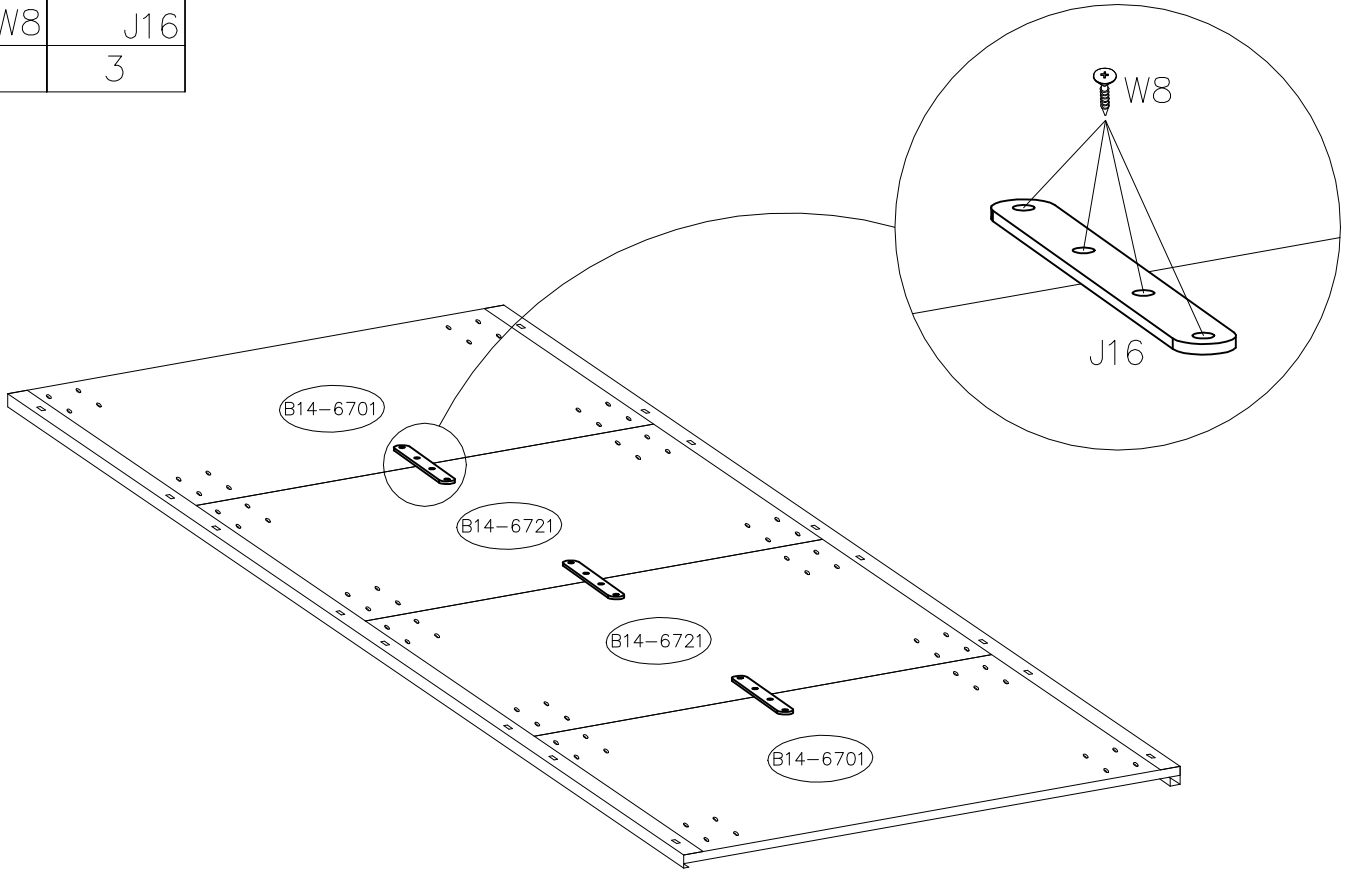

3.5x13	
W8	J16
12	3

18b



3.5x13	
W8	J16
12	3

19b

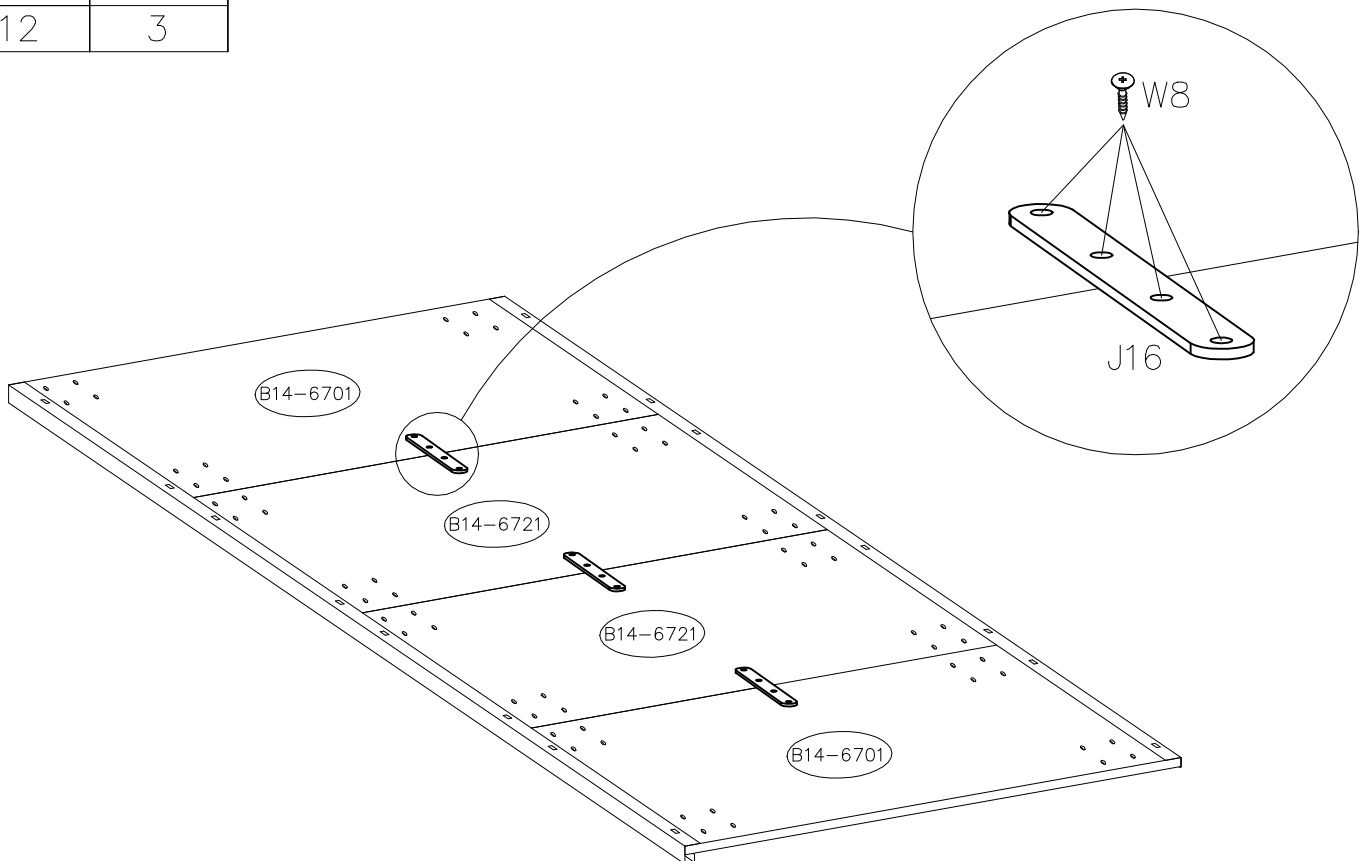

6.3x13



F



S92



S93



S142

12

1

1

2

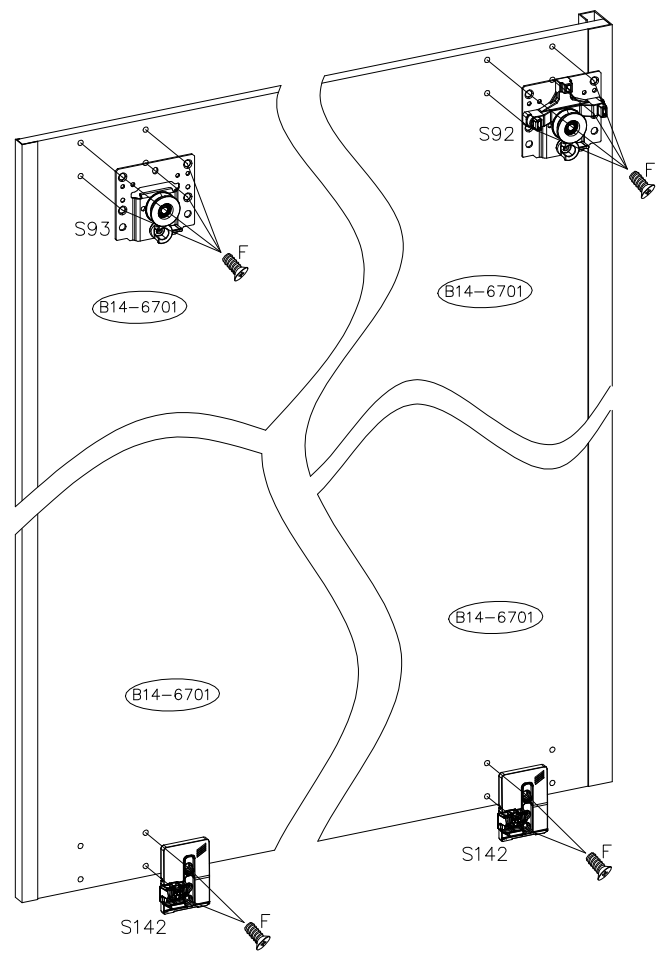



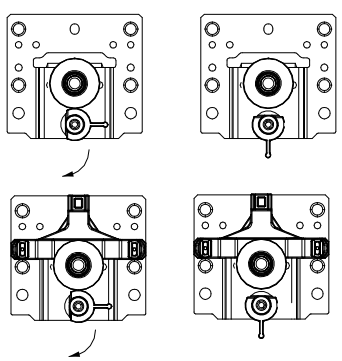

2

1

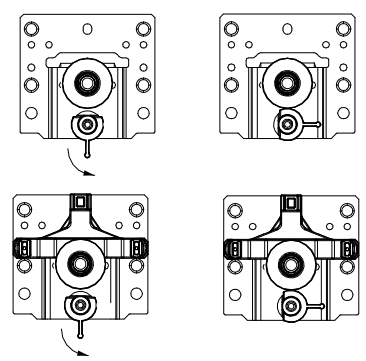

3

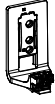

6.3x13  F	 S94	 S95	 S143
12	1	1	2

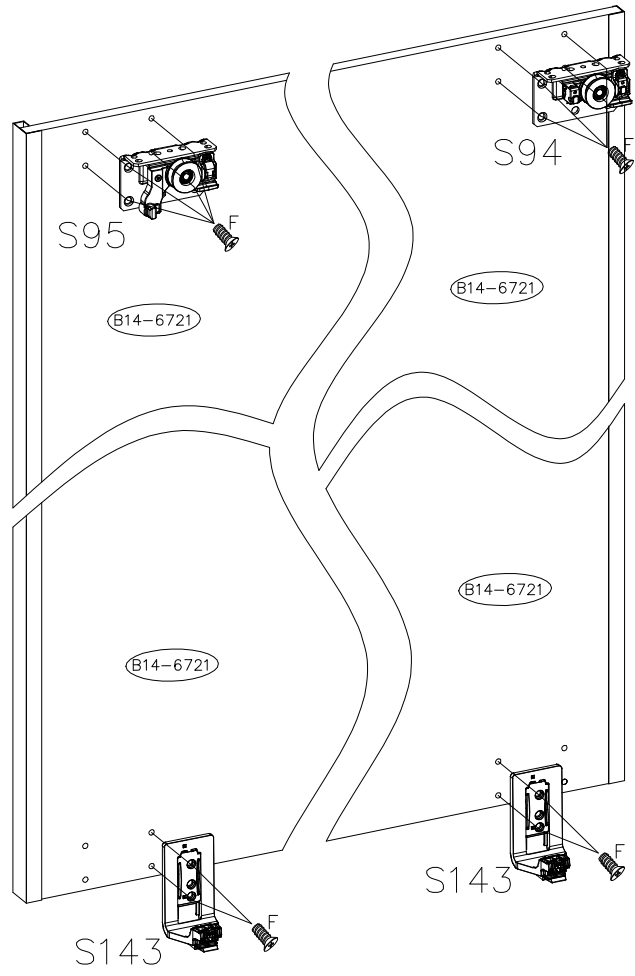

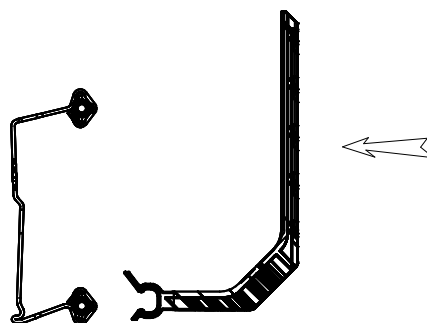
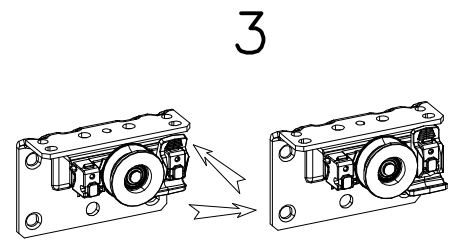
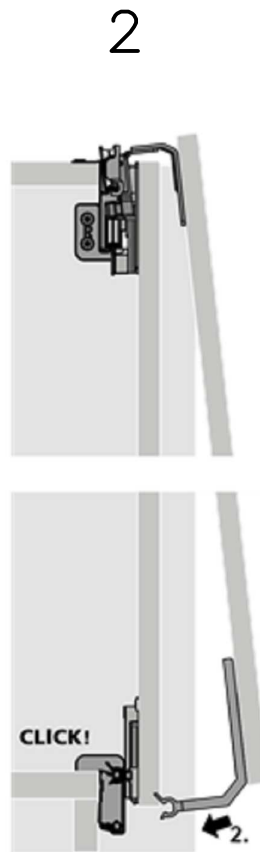
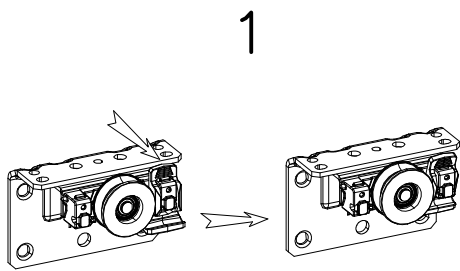

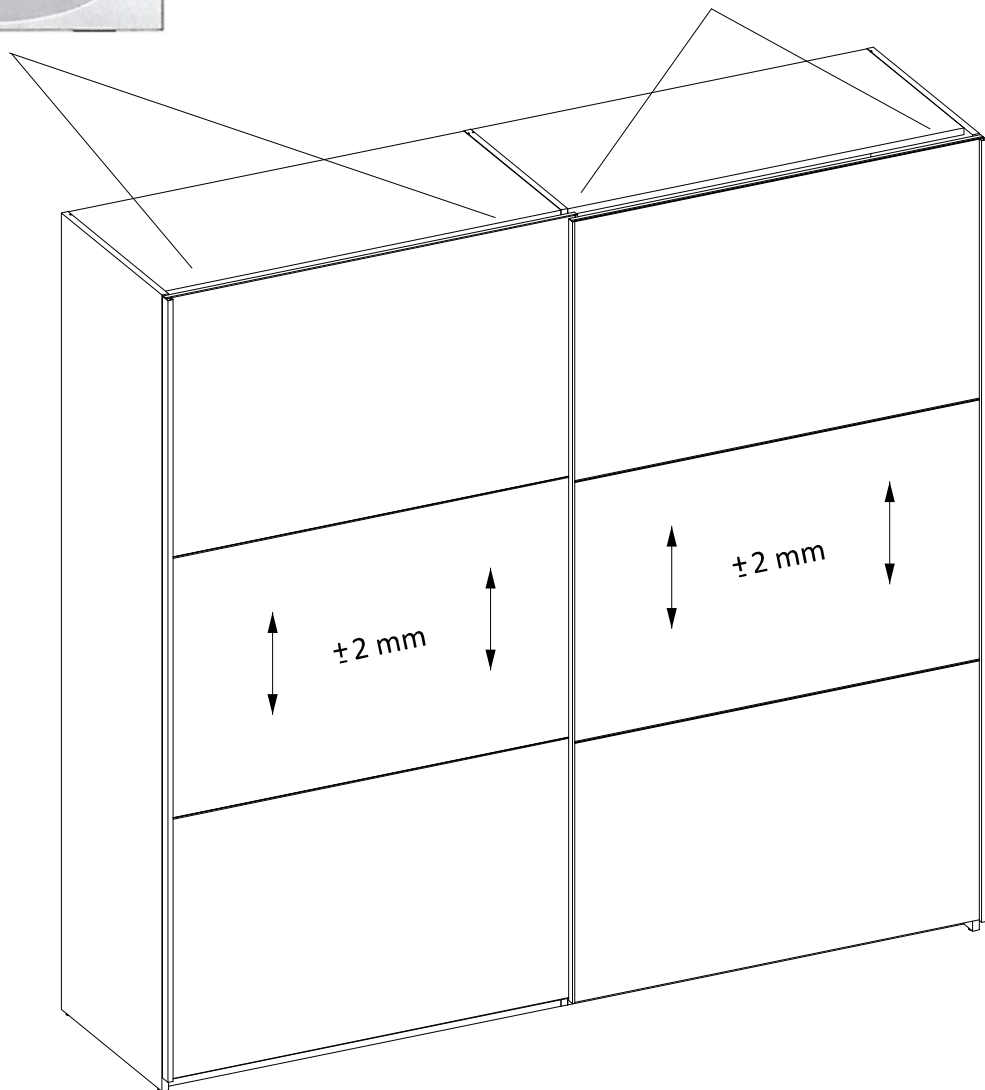
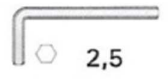
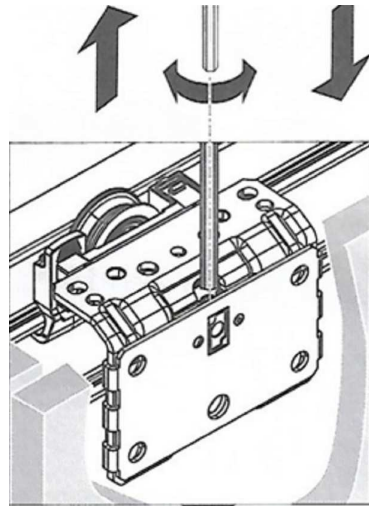
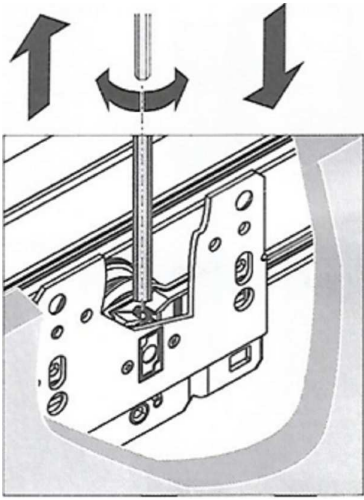

1

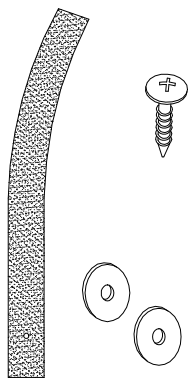

Uwaga • Upozornini • Achtung • Attention • Caution • Figyelem Attenzione • Opgelet • Внимание • Atentie • Upozornenie • Dikkat	
PL	Mocowanie do ściany jest jednocześnie zabezpieczeniem przed przewróceniem – koniecznie zamontować!
CZ	Do některých druhů stěn koniečně použít speciální hmoždinka. Montáž na stěnu slouží jako ochrana proti převrnutí – bezpodmínečně umístěte! U některých typů stěn může být zapotřebí speciální hmoždinka!
D	Wandbefestigung dient als Kippschutz – unbedingt anbringen! Bei einigen Wandtypen kann ein Spezialdübel erforderlich sein!
GB	The wall fastening serves to prevent tipping – be absolutely sure to mount it! For certain wall types, a special wall plug may be necessary!
FR	La fixation murale sert de protection contre le basculement – à installer impérativement ! Pour certains types de murs il faut des chevilles spéciales !
NL	Bevestiging aan de muur dient als kantelbescherming – zeker en vast bevestigen! Bij enkele muurtypes is een speciale plug misschien vereist!
IT	Il fissaggio alla parete serve da protezione anti-ribaltamento – attaccarla assolutamente! Per alcune strutture di parete può essere necessario un tassello speciale!
HU	A termékét a falhoz kel rögzíteni, különben az felborulhat! Egyes faltípusoknál speciális tiplit kell használni!
RU	Обязательно установите крепление на стене во избежание опрокидывания! Для некоторых типов стен может потребоваться специальная дюбель!
RO	Sistemul de fixare la perete servește ca protecție la răsturnare – de montat obligatoriu! Pentru unele tipuri de pereți este posibil să fie necesar un diblu special!
SK	Upevnenie na stenu slúži ako ochrana proti prevráteniu – bezpodmienečne použite! Pre niektoré druhy stien môže byť potrebná špeciálna hmoždinka!
TR	Duvardaki sabitleme, devrilmeye karşbir emniyet tedbiridir ve mutlaka monte edilmelidir! Bazıduvar tiplerinde bunun için özel bir dübel gerekli olabilir!

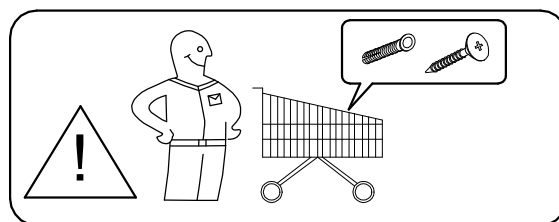
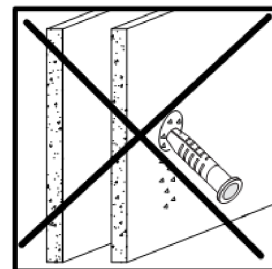
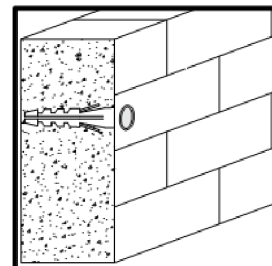

2a

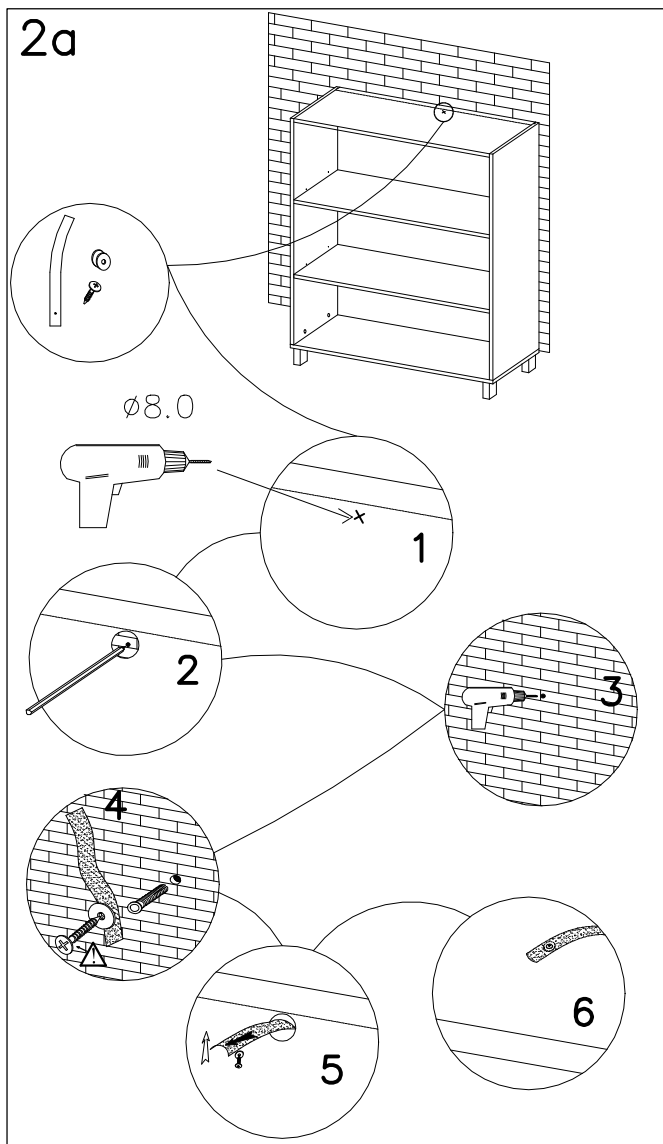

2b

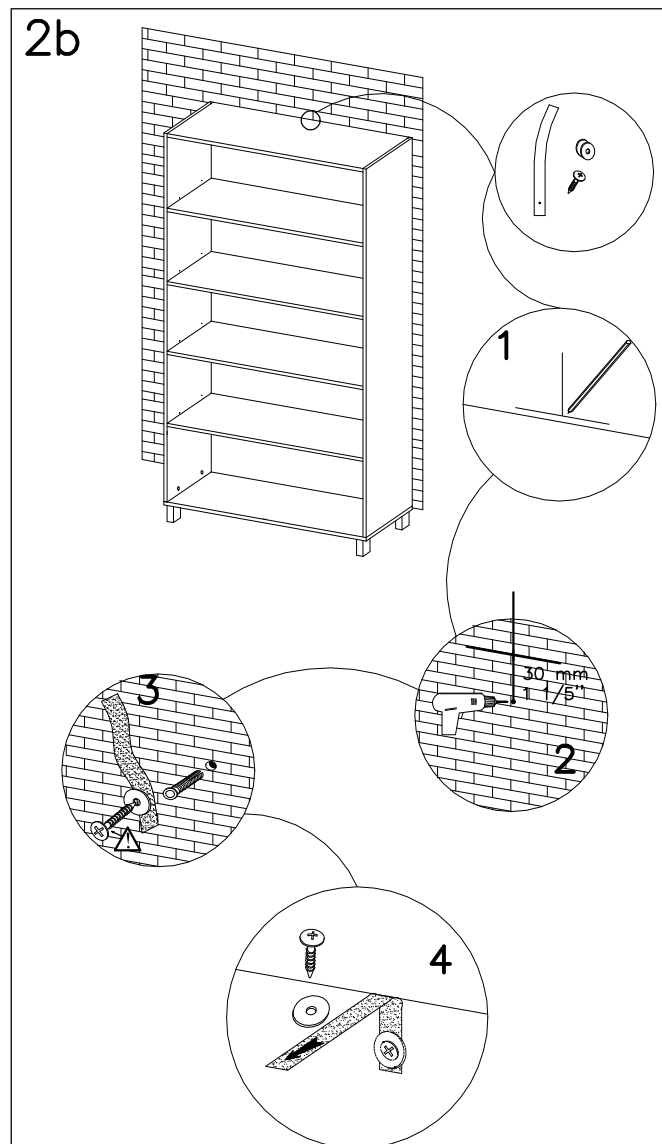

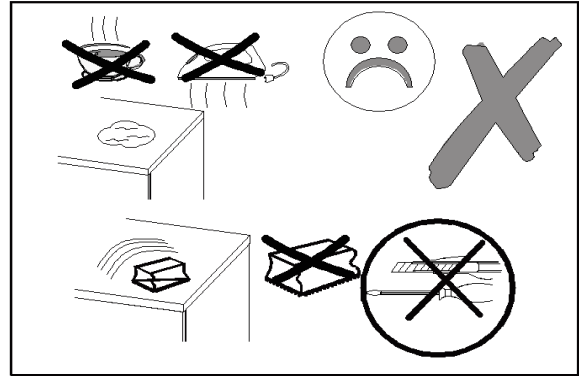
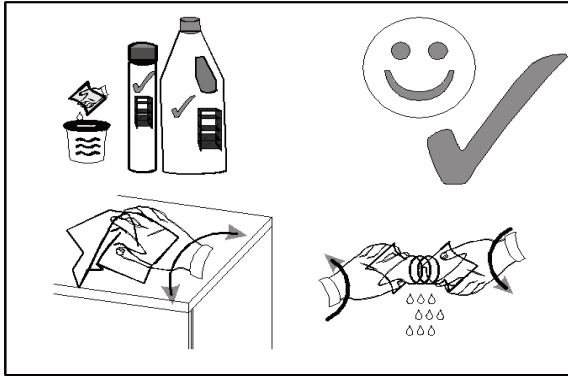

PL- Wskazówki dotyczące pielęgnacji mebli z płyt drewnopochodnych

Do czyszczenia używać czystej, suchej i miękkiej tkaniny. Jeżeli meble wymagają dokładniejszego czyszczenia można ją lekko zwilżyć wodą lub środkiem czyszczącym przeznaczonym do czyszczenia mebli, a następnie wytrzeć czyszczone elementy do sucha. Części metalowe i szklane czyścić dostępnymi w handlu środkami przeznaczonymi do czyszczenia tego typu materiałów zgodnie z umieszczoną na nich instrukcją.

Nie używać środków żrących, szorujących i innych o nie wiadomym przeznaczeniu. Środki czyszczące muszą mieć wyraźne oznakowanie że są przeznaczone do czyszczenia mebli.

UWAGA!!! Elementy w wysokim połysku, z których usunięto folię ochronną można czyścić i użytkować dopiero po upływie 72 godzin.

CS-Doporučení pro péči o nábytek vyrobený z panelů na bázi dřeva

K čištění použijte čistý, suchý a měkký hadřík. Vyžaduje-li nábytek důkladnější čištění, navlhčete hadřík lehce vodou nebo čistícím prostředkem určeným k čištění nábytku, poté vyčištěné prvky vytřete do sucha. Skleněné a kovové prvky by měly být čištěny prostředky určenými k čištění tohoto typu materiálu v souladu s pokyny k jejich použití.

Čistící prostředky musí mít zřetelné označení, že jsou určeny k čištění nábytku, nepoužívejte prostředky neznámého účelu, žíravé a abrazivní prostředky.

POZOR!!! Po odstranění ochranné fólie z lesklých prvků je lze vyčistit a používat až po 72 hodinách.

DE-Pflegetipps für Möbel aus Holzwerkstoffen

Verwenden Sie zur Reinigung ein sauberes, trockenes und weiches Tuch. Wenn die Möbel gründlicher gereinigt werden müssen, befeuchten Sie den Stoff leicht mit Wasser oder einem für die Möbelerreinigung vorgesehenen Reinigungsmittel und wischen Sie die gereinigten Gegenstände anschließend trocken. Reinigen Sie Glas- und Metallteile mit Mitteln, die für die Reinigung solcher Materialien vorgesehen sind, gemäß den dort angebrachten Anweisungen.

Reinigungsmittel müssen deutlich gekennzeichnet sein, dass sie für die Reinigung von Möbeln bestimmt sind. Verwenden Sie keine Produkte mit unbekanntem Verwendungszweck, die ätzend sind oder zum Schrubben verwendet werden.

ACHTUNG!!! Sobald die Schutzfolie von den glänzenden Teilen entfernt wurde, können diese erst nach 72 Stunden gereinigt und verwendet werden.

GB-Tips on how to properly take care of furniture made of wood-based panels

Use a clean, dry and soft cloth for cleaning. If the furniture requires more thorough cleaning, slightly dampen the cloth with water or a cleaning agent dedicated to furniture and then wipe the cleaned elements dry. Clean glass and metal parts with cleaning agents intended for such materials in accordance with the instructions.

Cleaning agents must be clearly labelled as designated for furniture cleaning. Do not use agents of unknown purpose, corrosive agents or abrasive agents.

CAUTION!!! After removing the protective film from glossy items, they may be cleaned and used after 72 hours.

FR-Les conseils concernant l'entretien des meubles en panneaux à base de bois

Pour le nettoyage, utilisez un chiffon propre, sec et doux. Dans le cas où le meuble nécessite un nettoyage plus soigné, humidifiez légèrement le chiffon avec de l'eau ou un détergent conçu pour le nettoyage des meubles, puis essuyez les éléments nettoyés. Les éléments en verre et en métal doivent être nettoyés avec des produits de nettoyage prévus pour ce type de matériau, conformément aux instructions qui y sont indiquées.

Les produits de nettoyage doivent comporter une étiquette indiquant distinctement qu'ils sont prévus pour le nettoyage des meubles. N'utilisez pas de produits dont la destination est inconnue, ni de produits caustiques ou abrasifs.

NOTE !!! Après avoir enlevé le film protecteur des parties vernies, celles-ci ne peuvent être nettoyées et utilisées que dans un délai de 72 heures.

HU-Faredetű lemezekből készült bútorok ápolására vonatkozó útmutatók

Tisztításhoz tiszta, száraz és puha ruhát használjon. Ha a bútor pontosabb tisztítást igényel, a ruhát kissé nedvesítse vízzel vagy bútorápoló tisztítószerezrel, majd szárazra törölje a tisztított elemeket. Üveg- és fémelemeket az ilyen típusú anyagok tisztítására alkalmas szerekkel tisztítson, az azokon megadott használati útmutatónak megfelelően.

A tisztítószereknek kifejezett jelzéssel kell rendelkeznie, hogy a bútorok tisztítására alkalmas, ne használjon ismeretlen rendeltetésű, maró hatású vagy súroló szereket.

FIGYELEM!!! Csillagó kivitellű bútorok védőfóliájának eltávolítását követően a bútorok csak 72 óra letelte után tisztíthatók és használhatók.

IT-Consigli per la cura dei mobili realizzati con pannelli a base di legno

Spolverare il mobile con un panno pulito, asciutto e morbido. Se i mobili richiedono una pulizia più accurata, inumidire leggermente un panno con acqua o un detergente specifico per la pulizia dei mobili e poi asciugare gli elementi puliti. Pulire gli elementi in vetro e metallo con prodotti destinati alla pulizia di questo tipo di materiale secondo le istruzioni su di essi. I detersivi devono avere un'etichetta chiara indicante che sono destinati alla pulizia dei mobili. Non utilizzare agenti per cui la destinazione non è nota o agenti corrosivi e abrasivi.

ATTENZIONE!!! Dopo aver rimosso la pellicola protettiva dagli elementi in lucentezza, possono essere puliti e utilizzati solo dopo 72 ore.

NL-Tips voor het onderhoud van meubelen van houten panelen

Gebruik voor het schoonmaken een schone, droge en zachte stof. Als het meubel grondiger moet worden gereinigd, bevochtigt de stof dan lichtjes met water of een reinigingsmiddel dat bestemd voor de meubelreiniging is en veeg de gereinigde delen vervolgens droog. Reinig glas en metalen onderdelen met schoonmaakmiddelen die bedoeld zijn voor het reinigen van dergelijke materialen, volgens de daarop aangebrachte instructies.

Op het etiket van de reinigingsmiddelen moet duidelijk worden vermeld dat zij bestemd zijn voor het reinigen van meubelen; gebruik geen middelen waarvan het doel onbekend is, die bijtend zijn of om te schrobben.

LET OP!!! Zodra de beschermfolie van glanzende elementen verwijderd is, kunnen ze pas na 72 uur worden gereinigd en gebruikt.

RU-Советы по уходу за мебелью из древесно-стружечных плит

Для очистки используйте чистую, сухую и мягкую ткань. Если мебель требует более тщательной очистки, слегка намочите ткань водой или чистящим средством, предназначенным для чистки мебели, затем вытрите очищенные элементы насухо. Стекло и металлические элементы следует очищать средствами, предназначенными для очистки данного вида материала, в соответствии с размещенными инструкциями на них.

Чистящие средства должны иметь четкую маркировку о том, что они предназначены для чистки мебели, не используйте средства неизвестного назначения, едких и абразивных.

ВНИМАНИЕ!!! После удаления защитной пленки с глянцевых деталей их можно мыть и использовать только через 72 часа.

SK-Odporúčania pre starostlivosť o nábytok vyrobený z panelov na báze dreva

Na čistenie používajte čistú, suchú a mäkkú handričku. Ak si nábytok vyžaduje dôkladnejšie čistenie, navlhčite handričku ľahko vodou alebo čistiacim prostriedkom určeným na čistenie nábytku, potom vyčistené prvky vytrite do sucha. Sklenené a kovové prvky by sa mali čistiť prostriedkami určenými na čistenie tohto typu materiálu v súlade s pokynmi na ich použitie.

Čistiace prostriedky musia mať zreteľné označenie, že sú určené na čistenie nábytku, nepoužívajte prostriedky neznámeho účelu, žieravé a abrazívne prostriedky.

POZOR!!! Po odstránení ochrannej fólie z lesklých prvkov je možné ich vyčistiť a používať až po 72 hodinách.

TR-Ahşap bazlı levhadan imal edilmiş mobilyanın bakımına ilişkin talimat

Temizleme için temiz, kuru ve yumuşak bez kullanın. Daha da etkili temizleme için bezi hafice su veya mobilya için imal edilmiş madde ile ıslatın. Akabinde mobilyayı iyice kurulayın.

Cam ve metal parçaları cam ve metal temizlemek için imal edilmiş madde ile temizleyin. Bu itibar ile ilgili talimatı uygulayın.

Temizlik malzemesi üzerinde, mobilya temizlemek için üretildiğine dair bilgi bariz bir şekilde gösterilmelidir. Bu tür bilgisi olmayan maddeler, aşındırıcı ve çizik yapan maddeleri kullanmayın.

DİKKAT!!! Parlak yüzeyli parçaların üzerinden koruyucu folyo çıkarıldıktan sonra ancak 72 saat geçince o tür parçaları temizleyebilir ve kullanabilirsiniz.

ES-Consejos para el cuidado de los muebles de los tableros a base de madera

Para limpiar las superficies, utilice un paño limpio, seco y suave. Si el mueble requiere una limpieza más exhaustiva, moje ligeramente el paño con agua o un producto de limpieza pensado para la limpieza de muebles y luego seque las partes limpiadas con un paño. Limpie los elementos de cristal y metal con productos de limpieza destinados a la limpieza de dichos materiales siguiendo las instrucciones colocadas en los mismos.

Los productos de limpieza deben estar claramente etiquetados como destinados a la limpieza de muebles: no se deben utilizar productos de uso desconocido, corrosivos o destinados a frotar.

¡OJO! Una vez retirada la película protectora de las partes en brillo, sólo podrán limpiarse y utilizarse pasadas 72 horas.

SR-Saveti za negu nameštaja od panela na bazi drveta.

Za čišćenje koristite čistu, suhu i meku krpu. Ako nameštaj zahteva temeljnije čišćenje, blago navlažite tkaninu vodom ili sredstvom za čišćenje namenjeno čišćenju nameštaja, a zatim obrišite očišćene elemente dok ne budu suvi. Staklene i metalne elemente čistiti sredstvima namenjenim za čišćenje ove vrste materijala u skladu sa uputstvima na njima.

Sredstva za čišćenje moraju imati jasnu oznaku da su namenjena za čišćenje nameštaja, ne koristiti sredstva nepoznate namene, korozivna sredstva i sredstva za ribanje.

OPREZ!!! Nakon uklanjanja zaštitnog filma sa sjajnih elemenata, oni se mogu očistiti i koristiti tek nakon 72 sata.

HR-Savjeti za njegu namještaja izrađenog od ploča na bazi drva

Za čišćenje koristite čistu, suhu i meku krpu. Ako namještaj zahtijeva temeljitije čišćenje, blago navlažite tkaninu vodom ili sredstvom za čišćenje namijenjenim čišćenju namještaja, a zatim očišćene elemente obrisati dok ne budu suhi. Staklene i metalne elemente treba čistiti sredstvima namijenjenim za čišćenje ove vrste materijala prema uputama na njima. Sredstva za čišćenje moraju imati jasnu oznaku da su namijenjena čišćenju namještaja, ne koristiti sredstva nepoznate namjene, nagrizajuća sredstva i sredstva za ribanje.

OPREZ!!! Nakon uklanjanja zaštitne folije sa sjajnih elemenata, oni se mogu čistiti i koristiti tek nakon 72 sata.

PT-Dicas para cuidar de móveis feitos de painéis derivados da madeira Para a limpeza use um pano limpo, seco e macio. Se os móveis exigirem uma limpeza mais profunda, haverá de molhar o pano levemente com água ou um produto de limpeza próprio para móveis e, a seguir, secar os elementos limpos. Os elementos de vidro e metal devem ser limpos com agentes próprios para a limpeza deste tipo de material de acordo com as instruções contidas nos mesmos. Os agentes de limpeza devem ter uma etiqueta clara, indicando que se destinam à limpeza de móveis. Não se pode usar agentes de desconhecidos, corrosivos e abrasivos.

CUIDADO!!! Após a remoção da película protetora dos elementos brilhantes, os mesmos só poderão ser limpos e usados após 72 horas.